

## WAW-1000D

### Computer Control Electro-Hydraulic Servo Universal Testing Machine



**BMS Bulut Makina Sanayi ve Ticaret Ltd. Şti.**

Kocaeli KOBİ Organize Sanayi Bölgesi  
Köseler Mahallesi, 6.Cadde No: 20/2 Dilovası / KOCAELİ / **TURKEY**

Phone: +90 262 502 97 73-76 / +90 262 503 06 51

Web: [www.bulutmak.com](http://www.bulutmak.com) e-mail: [bms@bulutmak.com](mailto:bms@bulutmak.com)

1	Main application .....	3
2	Technical specifications .....	3
3	Control system case weight (kg):300Standard Accessories .....	4
4	Working conditions .....	4
5	Features and working principle .....	5
5.1	Load frame .....	6
5.2	Working cylinder & Ram .....	6
5.3	Moving cylinder and driving system.....	6
5.4	The installation of position-limited switch of ram stroke. ....	6
5.5	Oil Source & working Principles .....	7
5.6	Safety Device .....	7
5.7	Accessories for test.....	7
6	Hoisting & Storage .....	7
7	Installation & Adjustment .....	7
7.1	Installation Conditions .....	7
7.2	Installation of load frame .....	7
7.3	Piping Connection .....	8
7.4	Choosing of Specification of Liquid .....	8
7.5	Filling and Draining of Oil.....	8
7.6	Electric Connection .....	8
8	Operation .....	8
8.1	Primary Running of Oil Pump .....	8
8.2	Preparation before operations.....	8
8.3	Test Procedures .....	8
8.4	Clamping the test specimen.....	9
8.5	Compression Test.....	9
8.6	Bending Test .....	9
8.7	Shearing Test.....	9
8.8	Adjustment of test space .....	9
8.9	Precaution.....	9
9	Maintenance.....	9
10	Troubles & Remedies .....	9

## REMARKS

Thanks for choosing our Model WAW-1000D testing machine. Please read this manual carefully before usage, and then operate on the basis of full understanding.

Please take good care of your machine & operate in proper way so as to keep the machine in high precision & good condition.

After installing and fixing the machine, it should dismantle the side plates pressed by the bolts on the top of two screws, and then connect the power.

During the test, it is forbidden to start loading and unloading of the crosshead! The function of moving crosshead is to adjust the test space. If error operation, it will lead to troubles, such as the broken of chain in the driving structure, and lock of the moving crosshead.

After usage of testing machine for some time, it should check the loose degree of chain, if the chain is loose, please adjust it tight through the screws on the back of chain wheel bracket.

The machine can control manually and software automatically, when do software automatic control, please screw the oil inlet valve and oil outlet value on the control cabinet tightly, because manual control is easy, so no more detailed information offered.

### 1 Main application

The tester adopts load frame with oil cylinder at the bottom, electro-hydraulic servo oil source, and imported oil pump. Equipped with double-channel Full Digital Processing-Controlled Amplifier, it features as intelligent expert system. It can realize closed loop control of test load, specimen deformation & piston displacement etc. The software package features as virtual program technologies, it realizes the digital display of test load, peak value, piston displacement, specimen deformation & test curves. By adopting the intelligent expert system, the customers can have self-control Mode functions. Furthermore, the software package conforms to ISO6892. The machine is mainly used to carry on various kinds of tension, compression and bending and shearing test for metal and non-material materials. It is ideal testing equipment for production, research & education Industries & widely used in the field of Building Materials, metallurgy, research & Institute, colleges & universities, quality inspection center & commodities Inspection Department.

### 2 Technical specifications

Max load: 1000KN

Effective load range: 20-1000kN

Load accuracy:  $\leq \pm 1\%$

Deformation accuracy:  $\leq \pm 1\%$

Driving method: Hydraulic system

Test curves' mode: Load - deformation, Load - time, Load-Displacement, Stress-Strain, Time-Stress, Time-Strain, Deformation-Time, Displacement-Time, etc

Velocity display mode: loading velocity, strain velocity

Parameters processed with computer: Upper & lower yield point strength  $R_{eH}$  &  $R_{eL}$ , max. load point, breaking strength, stress, deformation, elongation rate, elastic modulus &  $\sigma_{P0.2}$ .etc.

Control mode: Displacement control; Load control; Strain control; Stress Control.

Max. Tensile space: 600mm (Including ram stroke)

Clamps for flat specimen: Thickness 0-40mm

Clamps for round specimen: Diameter  $\varnothing$  4-45mm

Max. Effective Compression space: 520mm

Compression plate diameter: Ø 120mm  
 Bending test effective space: 480mm  
 Ram stroke: 200mm  
 Crosshead lifting speed: 180mm/min  
 Testing Speed control range: 0-50mm/min  
 Load measuring mode: Load cell  
 Displacement measuring mode: Photoelectric encoder  
 Deformation measuring mode: Extensometer  
 Power supply: 380VAC, 50Hz, 3-Phase  
 Main unit dimensions (mm):800\*750\*2180  
 Main unit weight (kg):2600  
 Main unit case dimensions (mm):2470\*930\*960  
 Main unit case weight (kg):2700  
 Control system dimensions (mm):1100\*700\*930  
 Control system weight (kg):250  
 Control system case dimensions (mm):1290\*990\*1400  
 Control system case weight (kg):300

### 3 Control system case weight (kg):300 Standard Accessories

Main unit with complete hydraulic system	1
Hand control unit	1
Flat Sample Grip (0-15 mm) each one pair	1
Round Sample Grip (Φ13~Φ26) one pair	1
Round Sample Grip (Φ26~Φ40) one pair	1
Compression fixture (Φ 160 mm)	1
Lower platen and upper platen	1
Load cell	1
TMC 100 External independent controller	1
Safety door	1
Bending system complete	1
Electronic Extensometer- gauge length 100 mm, deform.25 mm	1
Computer system -WIN10 English version with int. registration (PC case+ screen +keyboard +mouse+ Evotest software (in English) +printer)	1
EVOTEST software (English) in CD for back-up purpose	1

### 4 Working conditions

The machine should be operated under conditions below.

Temperature: 10-35°C

Relative humidity: ≤ 80%

Voltage fluctuation: ≤ 10% of rated voltage; Power frequency 50 Hz

No impact and vibration around.

No evident disturbance from electro-magnetic field, no erosive media around.

The machine will be installed on the stable, strong and level foundation, and the level grade shouldn't exceed 0.2/1000.

## 5 Features and working principle

This machine consists of below components.

Load frame: working device for adding load to specimen.



Control cabinet: control device for starting & stopping the machine and control on or off of the oil pump.



Oil source: offer high-pressure oil to hydraulic system, driving device for adding the load to specimen through the load frame. The oil source is inside of the Control cabinet.

Controller: It is used to control the testing machine and data acquisition, amplification, and it is the head of the control system.

Computer control system & printer: the device for controlling test procedures, display, processing and print.



## 5.1 Load frame

The load frame mainly consists of adjustable height supporting frame (Includes base, screws and moving crosshead) and working frame (Includes working cylinder, ram, working table, columns and upper crosshead).

Its working principle is that high-pressure oil will enter into the working cylinder, so the working cylinder will move to drive the working table and upper crosshead lift upward to do tensile and compression test. When apply the load on the specimen, the load cell will transfer the signal of reflecting voltage changing into the computer system. The deformation signal when do tensile test will be transferred into computer system through the extensometer. The displacement signal when do tensile test will be transferred into computer system through photoelectric encoder. Thus, the computer system will acquire the signals of load, deformation and displacement, which can control test procedures according to different test request, meanwhile display test data and test curve in real time.

Tensile test will do between upper crosshead and moving crosshead, the compression test will do between working table and moving table. The test space can be adjusted through the elevating of moving crosshead driven by driving system.

## 5.2 Working cylinder & Ram

Cylinder and ram are the important components of testing machine. The cylinder is fixed on the base of the machine, and there is a ball head between ram and test bench; Return travel is done by the self-weight; The seal of pressure oil is done by the oil film between cylinder and ram. Take the inner surface of cylinder as leading, also due to the function of adjusting center of ball head, which will reduce the friction force between cylinder and ram exerted by side force.

## 5.3 Moving cylinder and driving system

Moving crosshead is installed on the nuts supporting on lead screws, and lead screws can revolve negatively and positively. The lead screws can be driven to revolve by the driving system installed on the base.

Driving system is made up of speed-reducing motor, chain wheel, chain, the lead screws can revolve driven by chain and chain wheel through speed-reducing motor.

## 5.4 The installation of position-limited switch of ram stroke.

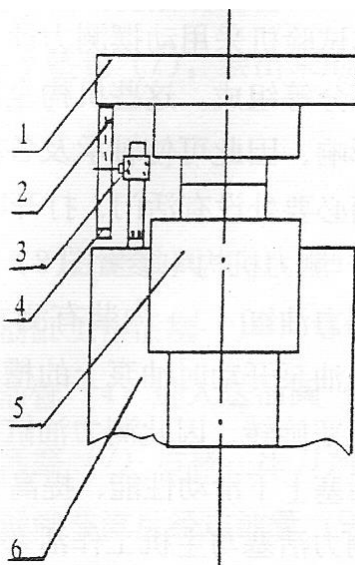

1. Test bench
2. Pulling plate for position-limited
3. Position-limited switch
4. Touching pole
5. Cylinder & Ram
6. Base

The position-limited switch is installed between test bench and base, the Pulling plate for position-limited will lift when lifting the ram, if the touching pole contacts with the extending spring pole, the power supply of oil pump will shut to realize safety.

## 5.5 Oil Source & working Principles

The oil source consists of oil tank, oil pump engine set, high pressure filter, retaining valve, electro-hydraulic servo valve, valve blocks & air filter etc.

Working principle of main hydraulic oil Source

The oil pump sets output the hydraulic oil which inlet into differential pressure valve inside valve blocks & servo valves on the blocks by single valve & high-pressure filter. According to the test input of the opening for control servo valve, Control system can control the test process automatically.

The output hydraulic oil from oil pump inlet into clamping blocks. Through controlling the electro-magnet reversing valve, the hydraulic oil can be driven into clamping cavity & loosening cavity inside of the clamping piston separately, therefore the test specimen can be clamped & loosened. Folding overflow valve can adjust the clamping system pressure.

Hydraulic working theory for clamping oil source: Hydraulic oil output from oil pump comes across the unidirectional valve into the valve block. By controlling the electro-magnet reversing valve, the oil goes into the clamping chamber or releasing chamber of clamping cylinder for crosshead. Therefore, fasten or loose the specimens. Stacked relief valve can be used for adjusting the system pressure for clamping.

## 5.6 Safety Device

When piston ascends to certain height, limit switch will act to send out signal, then pump stops.

When loading exceed 2%-5% of max. load, the test stops automatically.

## 5.7 Accessories for test

The machine is supplied with accessories for tension, compression, bending and shear tests (optional).

## 6 Hoisting & Storage

Choose the suitable hoisting equipment to hoist the machine according to its weight & volume. Make attentions to the hoisting position & center of gravity of package. The environment for storing testing machine should be at ventilation & dry places

## 7 Installation & Adjustment

### 7.1 Installation Conditions

The machine should be erected in a dry, clean room of uniform temperature. A sufficient space around the machine should be remained for bending test of long beam or applying any extensor meter and maintenance of the machine.

The machine body and oil source should be installation on concreted base, which size corresponds with overall dimensions and there should be sufficient space for foundation and wire piping. The surface of base should be leveled. Install the test machine when it is dry.

### 7.2 Installation of load frame

The foundation of testing machine is constructed according to foundation diagram.

Place pad at the center hole position of adjusting bolt hole of base on the foundation's surface and align bolt hole of base with center of base's hole. Then put sheet metal mat between the bottom of load frame & the base. Place square level with precision 0.05/1000 to make level. Put the square level on the surface of cylinder to check the perpendicularity of two upright side faces. The uprightness precision should be within 0.2/1000. Or set the gradiometer on the worktable & make level, the uprightness precision should be within 0.2/1000.

After regulation of machine's precision, cement anchors in concrete to firm iron pads under base. Fill gap under base with concrete. Keep good contact between base and cement foundation, avoiding no level of testing machine due to vibration during use. After cementing, before the cement isn't dry, don't tighten anchor (The dry time generally needs over 10 to 15 days). After cement is completely dried, fasten anchors and recheck the precision of testing machine. Looseness can appear during test because of vibration, so after using for some time, should fasten some parts.

### 7.3 Piping Connection

When installing hose connecting load frame with control console, should clear the ends of hose in kerosene to assure of clean of ends (Inside pipe is cleared before delivery. At the joint should be fitted with O-ring to prevent from leakage at high-pressure.

### 7.4 Choosing of Specification of Liquid

It is allowed to use testing machine special oil or other oils of similar specifications with VG 180 hydraulic oil may be used also.

### 7.5 Filling and Draining of Oil

Open iron door on the back of control console; the oil injection hole can be seen, through which oil is injected into oil tank. Inject 25L of oil every time. Take the oil gauge fitted on oil tank as standard.

When draining oil, opening oil-draining nozzle is OK. The use period of oil can be specified according to local climate and use conditions, usually, scheduled time is 1 year. If decomposition and contaminates are found, please replace them by new one.

### 7.6 Electric Connection

According to wiring diagram connect all the parts by plug board: including controller, load frame, oil source & computer. The connection should be correct, stable & reliable.

## 8 Operation

### 8.1 Primary Running of Oil Pump

After pushing the button "Power On" on the face of control cabinet, then starting the button "Pump On". When primarily running or after installation, there is air inside of the pipes. Noise will be here when the oil flows in the pipe. The correct method is applying a positive pressure signal, to let the piston go up in certain distance. Then apply a negative pressure signal, to let the piston down. To do this way after several cycles until the air in the pipe are exhausted. The test can be started.

### 8.2 Preparation before operations

Switch on the power, first turn on the computer & come into operation of software state. Then, press "Power On" on the top of control console & start the button "Pump On" .at once. Starting oil pump power set. When carrying on the tensile test, it is necessary to press the button of "clamping oil pump on" & to start clamping oil pump Motor. While completing compression test, it needn't to start the clamping pump.

### 8.3 Test Procedures

- 1). Select suitable shifts. When the max. test load couldn't be confirmed, select auto shifts.
- 2) Adjust the test load zero & re-set peak value.
- 3) Select control mode according to test requirements.
- 4) When selecting auto –process control, compile the auto control program.



- 5). During the auto control mode, press “start”, the test can be completed automatically.
  - 6). After completing the test, press “Fast Access” to store the test result. Press” Analyze” to analyze & calculate the test data.
  - 7) Printing test report
- Re-set the oil cylinder before continuing next test,  
Notes: Please refer to detail’s operation of test software “Instruction manual of software”

## 8.4 Clamping the test specimen

In tension test, the specimen should be clamped in full length of grips; the smallest is 2/3 of the grips and fixed on its center.

## 8.5 Compression Test

Install upper compression plate on the bottom of lower crosshead. With screw fixes plug. Lower compression plate and spherical seat are fixed with plug and set on working bench and tilt a little to suit the applied surface of specimen. Centerline of specimen must coincide with centerline of pressure disc, avoiding eccentric force. After that, conduct test at once.

## 8.6 Bending Test

Set support for bending test on working bench. Fix them with plug and positioning pin. According to required distance, graduation mark coincides with graduation of rod. Fix pressure support to working bench with nut and fix the support with bolt. Set upper pressure head on bottom of lower crosshead and tighten it with screw. (Notes: According to different variety and shape of specimens, make protection screen by self to avoid danger from breaching of specimen.

## 8.7 Shearing Test

Set shearing support on working bench. Movable shearing block is set between fixed shearing blocks, in which specimen inserts. Upper pressure head is fixed on lower movable crosshead with screw. Open inlet valve to lift working bench. Move shearing support to make upper head aim at active shearing block, conducting shearing test.

## 8.8 Adjustment of test space

Press Crosshead “Up” & “Down” buttons on the top of control console to move the crosshead lifting, therefore to adjust the test space.

## 8.9 Precaution

Not allowed loading by elevating motor for crosshead.

## 9 Maintenance

All parts of the machine should be wiped clean. For those surfaces, which are not painted, wiped them with a piece of cloth soaked with a little machine oil to prevent rusting, especially in rainy season. The machine should be covered with canvas cover when it's not in use to prevent dust. After each operation when the test bench is to be lowered, it is advisable to keep the working piston at a little instance above the bottom of the cylinder to facilitate next operation.

When the machine pauses temporarily, the motor of the pump should be stopped.

## 10 Troubles & Remedies

Oil connections occurs leakage.

Remedy: Return the piston falling down the bottom of oil cylinder, switch off oil pump & power & fasten the joints by hand tool. If there is still oil leakage, please exchange the assembled locking ring or O type ring.

*Clamping device for specimen*

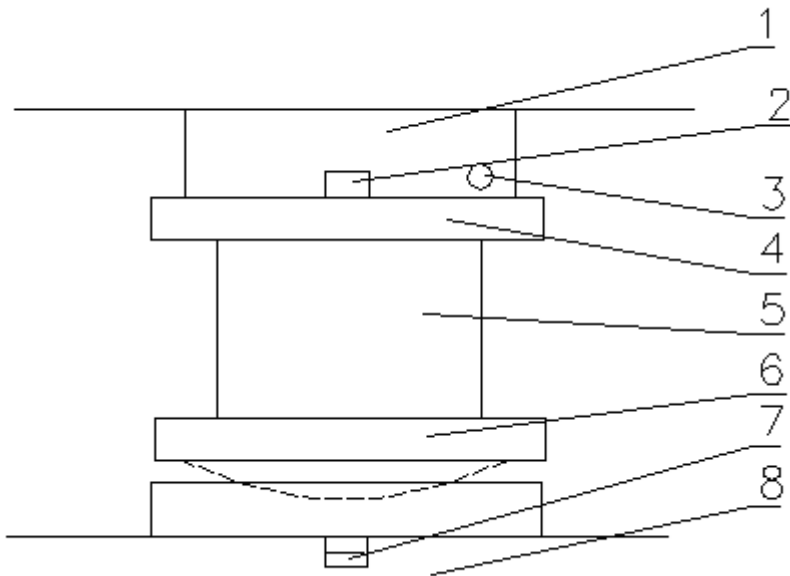
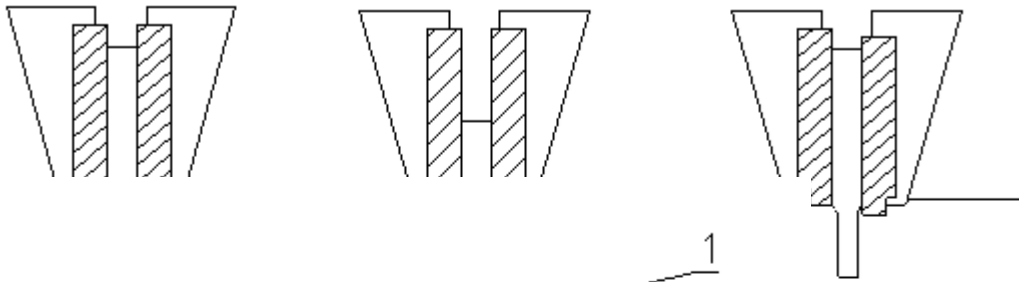

ng clamping  
 ot in alignment)

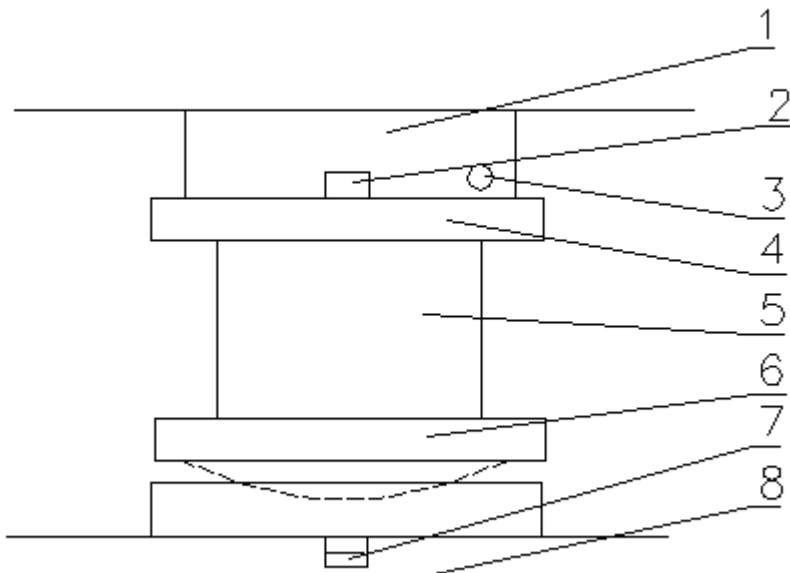

- 1.lower crosshead
- 2.pin
- 3.fasten bolt
- 4.upper compression plate
- 5.specimen
- 6.spherical seating on lower compression plate
- 7.pin
- 8.worktable

## Bending test

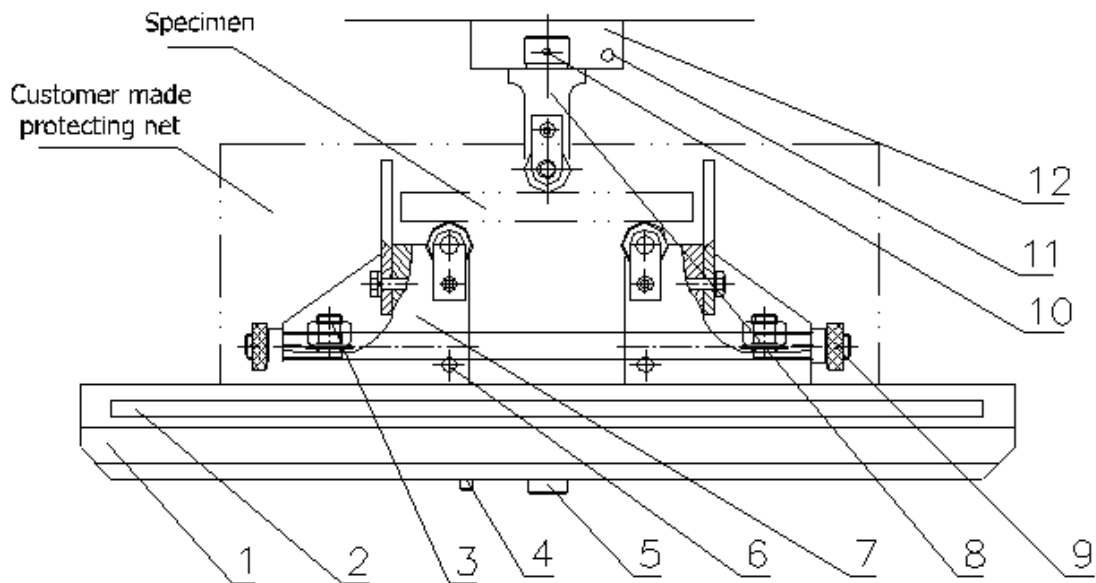

1. worktable for bending test
2. scale
3. nut
4. support for roller
5. fix pin
6. pin
7. scratch line
8. upper compression head
9. tension bolt
10. fasten bolt
11. bolt
12. upper crosshead

Electric principle

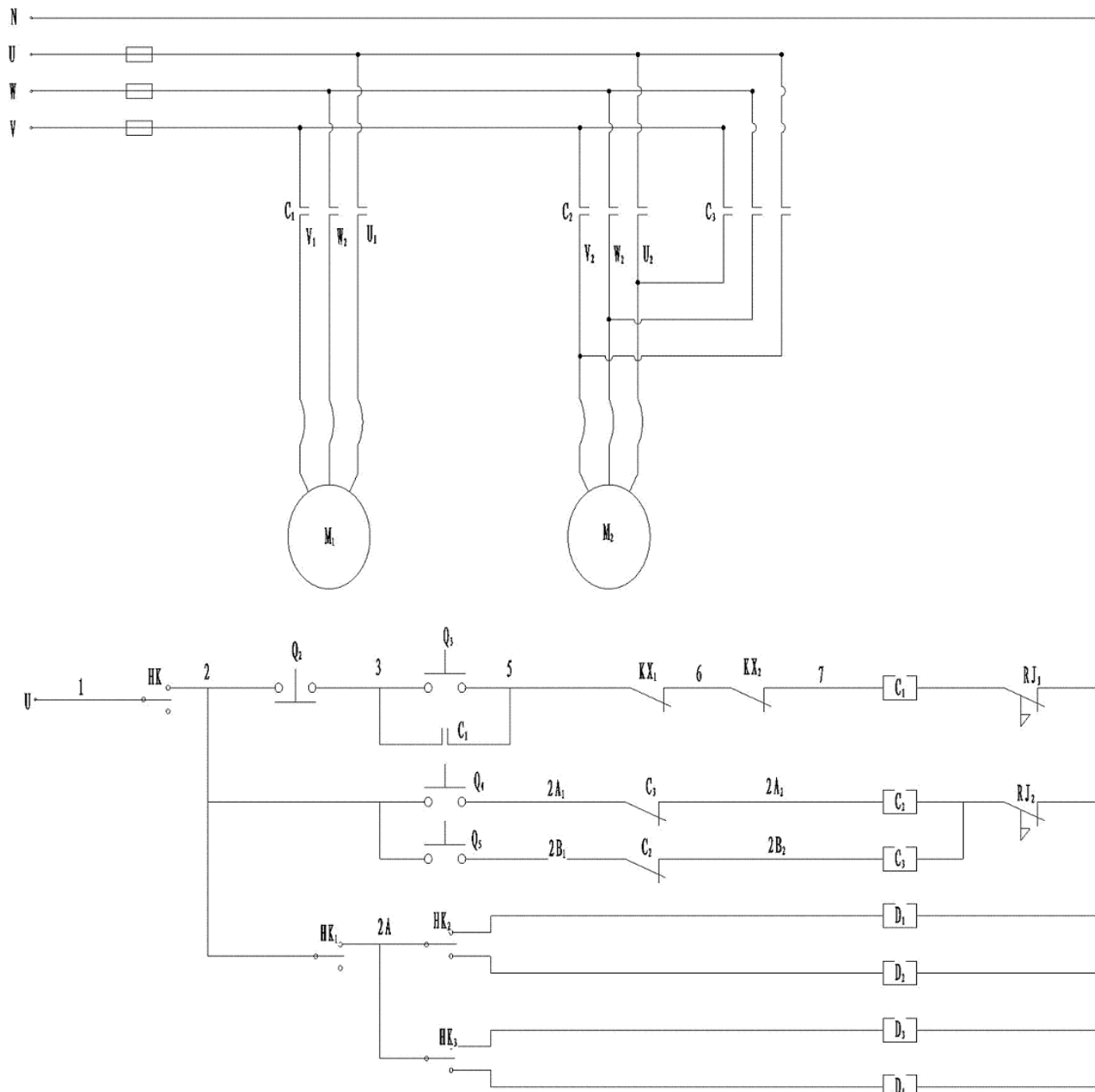

*Working theory of hydraulic system*

