

WDW-50

Computer Controlled Electromechanical
Universal Testing Machine



OPERATION MANUAL

BMS Bulut Makina Sanayi ve Ticaret Ltd. Şti.

Kocaeli KOBİ Organize Sanayi Bölgesi

Köseler Mahallesi, 6.Cadde No: 20/2 Dilovası / KOCAELİ / **TURKEY**

Phone: +90 262 502 97 73-76 / +90 262 503 06 51

Web: www.bulutmak.com e-mail: bms@bulutmak.com

1	Main application	4
2	Features	4
3	Main Specifications	4
3.1	Summarization	4
3.2	Standard Accessories	5
3.3	Speed-regulating system and servo electric motor	5
3.4	Measuring of the test load and specimen deformation	5
3.5	Displacement measuring system	5
3.6	Control and monitor system	5
3.7	Working conditions:	5
4	Structure and working principle	6
4.1	Structure of testing machine	6
4.2	Working principle	6
4.3	Accessories	6
4.3.1	Wedge gripping arrangement (seeing the attached figure 5)	6
4.3.2	Universal joint	6
4.3.3	Compression plates (seeing the attached figure 6)	6
4.3.4	Bend fixture (seeing the attached figure 7)	6
4.3.5	Shear fixture (seeing the attached figure 8, optional)	7
4.3.6	Measuring and transmission of the signal	7
4.3.7	Data processing	7
4.3.8	Lifting and conveying	7
4.4	Mounting and adjustment	7
5	Calibration of the test load and deformation	8
6	Mounting and removing of the accessories	8
6.1	Mounting and removal of the tensile accessories	8
6.1.1	Mounting of the wedge tensile accessory	8
6.1.2	Removal of the wedge gripping arrangement	9
6.2	Mounting and removing of the compression plates	9
6.2.1	Mounting of the compression plates	9
6.2.2	Removal of the compression plates	9
6.3	Mounting and removal of the bend fixture	9
6.3.1	Mounting of the bend fixture	9
6.3.2	Removal of the bend fixture	9
6.4	Mounting and removal of the shear fixture	9

6.4.1	Mounting of the shear fixture.....	9
6.4.2	Removal of the shear fixture.....	10
7	Operation	10
7.1	Operation and notices	10
7.1.1	Operation	10
7.1.2	Maintenance	11
7.1.3	Normal trouble and the way of removal	11

1 Main application

This machine is widely used for tension, compression, and bending etc. mechanics performance tests. It is suitable for many test fields such as quality supervision, teaching research, flight & aviation, steel & metallurgy, automobile, rubber, plastic, weaving etc. It meets the ISO, ASTM etc. standards.

2 Features

1. It realizes the close-loop control of test load, deformation, and displacement. With the test course control method intelligence setting specialist system, the user can set the control method of the test course according to his own demand. The PC control system can automatically establish the corresponding control arithmetic, and automatically control the test course according to the set method by the user.
2. It realizes the computer screen monitor of test load, displacement, deformation and test curves. It has functions of test condition and test result computer store and file operations. The test course control, the change of crosshead removal speed, and the test parameter input can be completed with the mouse, which makes the operation convenient.
3. It can process the test data according to the ISO, ASTM, DIN etc. standards. The process results and the test curves can be printed out for record. It also be stored by ASC II and convenient with data processing.
4. The test curves recorded during the test course have the reappearance function, which can let the user adopt the man-machine conversation to process the test data freely according to the demand. For example, the operator can input anyone of the test load, deformation, stress, and deformation at any point to get the other values.
5. Program controlled amplifier realizes the digit zeroing of the test load and deformation, automatic calibration, and the unity of the zero and indicating value, which make the operation easy, improving the reliability of the machine.
6. The software authority has the hierarchy manager function. It is easy for the hierarchy manager.
7. The user can specially order the data processing software that meets to other test method and test standard, to realize the automatic processing of the test result.
8. Without pollution, with low noise and high efficiency.

3 Main Specifications

3.1 Summarization

Max. Load (kN) : 50

Load accuracy : $\leq \pm 1\%$

Deformation accuracy: $\leq \pm 0.5\%$

Displacement resolution: 0.001mm

Speed: 0.01mm/min ~ 500mm/min

Tensile space: 600mm

Compression space: 600mm

Grips: Wedge type

Voltage: 220V, 1ph, 50Hz

Main unit dimensions (mm):780*590*1800

Main unit weight (kg):450

Main unit case dimensions (mm):730*860*1980

Main unit case weight (kg):500

Control system dimensions (mm): -

Control system weight (kg): -

For electromechanical universal testing machine, the control system is the computer + Control, and they will pack along with the load frame

- Control method: with test load, deformation, and displacement (speed) etc. three close-loop control functions, it can realize the control of constant test load, constant deformation & stress speed, and deformation speed. It requires the non-impact exchange during the test course.
- Protection: it has the overload and limit position protection function. It can prevent the overflow & over voltage, over speed, over torque, and over temperature of AC servo timing system and the electric motor.
- Tension and compression: The load frame is dual test spaces. The upper is for tension. The lower space is for compression and bending tests.

3.2 Standard Accessories

WDW-50 Computer Control Universal Testing Machine with following accessories	1
Main unit and Control box	1
Flat Sample Jaw (0-7 mm) each one pair	1
Round Grip ($\Phi 4 \sim \Phi 9$)	1
Compression fixture	1
Hand Control Unit	1
TMC 100 External independent controller	1
Electronic Extensometer ZES-100-25	1
Computer system -WIN10 English version with int. registration (PC case+ screen+ keyboard+ mouse+ Evotest software (in English) +printer)	1
EVOTEST software (English) in CD for back-up purpose	1

3.3 Speed-regulating system and servo electric motor

Adopting AC servo system and AC servo electric motor as the driving system, which with the high speed-regulating precision and steady performances

3.4 Measuring of the test load and specimen deformation

The test load measuring range: 0.4% ~ 100%FS, with the resolution 1/100000 of the full scale. The indicative accuracy is $\pm 1\%$, with the functions of measuring range automatic exchange, test load real-time monitor, and peak value keeping etc. The machine is equipped with an extensometer with 50mm gauge length and 25mm deformation. The deformation accuracy is better than $\pm 1\%F_s$, and the measuring system resolution is 0.005%F_s.

3.5 Displacement measuring system

- Resolution of the displacement measuring is 0.001mm.
- The crosshead moving is not more than 5mm, and the displacement error is not more than 0.02mm
- The crosshead moving is more than 5mm, and the displacement indicative error is $\pm 0.5\%$.

3.6 Control and monitor system

PC + Control & data processing software + controller & printer forms the control, data collecting, data processing, data storage, and test result printing etc. functions of the testing machine.

3.7 Working conditions:

1. Room temperature 10-35°C.
2. Relative humidity: $\leq 80\%$
3. Without vibration, corrosive medium and without strong electromagnetic field
4. The fluctuation of the electric power voltage is not more than the 10% of the rated voltage
5. Fixed on the firm foundation, with the levelness is 0.2/1000.

4 Structure and working principle

4.1 Structure of testing machine

This testing machine is made up with three parts: part of application, part of measuring and the part of recording, processing etc. The load frame and the accessories form the application frame of the testing machine. The AC servo electric motor, AC servo system and the decelerating system form the power driving system. The special controller, PC machine and the printer form the control and data processing & print system of the testing machine.

4.2 Working principle

Two guide columns, the upper crosshead, and the worktable form the doorframe table type load frame. The AC servo electric motor has features such as high speed-regulating accuracy, wide range, and steady performance etc. The electric motor drives the ball screw pairs turn through the decelerating system (sync tooth type belt structure), and the ball screw pairs drive the middle crosshead to bring along the tensile accessory (or compression, bending accessory) moving up and down. That realizes the loading and unloading of the specimen. This structure ensures the load frame has the enough stiffness, and at the same time realizes the high-efficiency & steady transmission. There exists the clearance eliminating mechanism between the lead screw and the nut, which improves the transmission precision of the testing machine. The load frame is dual testing space. The upper is for tensile and lower is for compression, bending and shearing.

4.3 Accessories

4.3.1 Wedge gripping arrangement (seeing the attached figure 5)

It takes wedge translation manual clamping structure. When manually clamping or losing the specimen, the clamps move up and down. But the inserts not move up and down. They only have translations left and right. That ensures that there is no pre-tension when clamping the specimen, and the operator can directly do the test after clamping the specimen, no need for adjustment. The clamps are equipped with 6 pairs of inserts. Three pairs of inserts for round specimen, with the clamping range is $\phi 4\text{mm} \sim 9\text{mm}$. Three pairs of inserts for flat specimen, with the clamping range is $0\text{mm} \sim 7\text{mm}$. The operator can change the different inserts with convenience according to the test demand.

When manually clamp or loose the specimen, the turning direction of the handle has been indicated on the clamps.

4.3.2 Universal joint

This part adopts cross bolt structure. This structure not only makes the turning flexible, but also limits the turning. It can localize the clamps firmly, meeting the special requirement of manual gripping arrangement. This part can decrease or eliminate the impact to the load cell because of the misalignment of clamping center and bearing center, when do the test of irregular specimen.

4.3.3 Compression plates (seeing the attached figure 6)

This part is made up with the upper and lower compression plates. The lower compression plate is curved concentric circle. When test, put the specimen in the center of concentric circle.

4.3.4 Bend fixture (seeing the attached figure 7)

This part is made up with the bases of upper & lower compression rollers, bending worktable, gauge and retaining mechanism (T-type lead screw). There are two T slots in the bending worktable. The base of upper & lower compression roller and the bending worktable are limited position by the two T slots. The graduations and the gauge fixed on the bending worktable indicating the relative position, when the above two on the proper relative positions, they are locked by the retaining mechanism.

4.3.5 Shear fixture (seeing the attached figure 8, optional)

This part is made up with the shearing compression head, knife-edge, supporting base and the shearing base. Put the specimen between the knife-edge and the supporting base, completing the shearing test through apply the test load to the shearing compression head and knife-edge. The diameter of the tested specimen is $\phi 10$.

4.3.6 Measuring and transmission of the signal

The load cell measures the test load, which is integral with the upper of the attachment. The deformation of the specimen is measured by the extensometer that clipped on the specimen. The displacement of the crosshead is measured by the photoelectric encoder that fixed on the ball screw. The above three signals realize the collecting, scale conversion, processing and screen monitor through the controller. According to the test requirement, the machine get the control signal after the calculation of the control system, magnify the signal via speed-regulating system, and then drive the servo electric motor. It does the test according to the control target of the control system until the test finished.

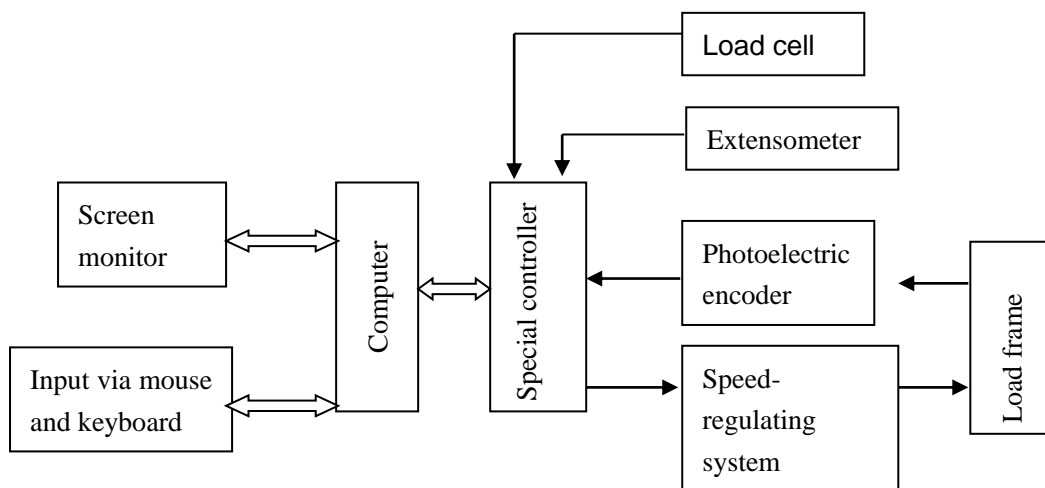

Diagrammatic sketch 1 system chart

4.3.7 Data processing

The data collected by the PC machine is not only monitored on the screen, but also stored in the memory of the computer. After the test finished, the user processes the test data, the test result can be printed out for record, or stored in the hard disk as the ASCII file, which makes it convenient for the later re-analysis and net operation of the data. (For details, please see the manual operation of *Software Usage*.)

4.3.8 Lifting and conveying

After unpacking the testing machine, please check whether the files, tools and accessories are completed according to the attachment paper. Then remove the bolt etc. clamp device that fixed the load frame on the packing box. Lifting the load frame with the soft rope according to the attached figure (4), putting it on the mounting position.

NOTES:

1. The elevating capacity of the lifting device should be more than 3T.
2. The outer cover of the testing machine is aluminum material, which cannot bear the weight.
3. Please carefully lift and put down the machine.

4.4 Mounting and adjustment

1. **Mounting of the load frame:** lifting the load frame according to the above VI step. Lightly pry the right (or the left) of the load frame with the crowbar, adjust the right level adjustment bolt, and then adjust the left level adjustment bolt.
2. **Note:** When pry the load frame with the crowbar, carefully put it. Prevent the painting of the machine from damaging.

3. **Mounting of the computer desk:** Unpack the accessory box, take out the whole computer desk, and mount it on the right of the load frame according to the mounting manual. The distance between the load frame and the desk is 200mm.
4. **Mounting of the host computer and the monitor:** Unpack the host computer and the monitor, and mount them according to the manual operation of the computer. Put the monitor on the center of the computer desk, and put the host computer under the desk.
5. **Mounting of the print:** unpack the printer, and mount it according to the manual operation of the printer. Put it on the right of the computer desk.
6. **Mounting of wire the electric appliance:** Collecting all the wires of the electric appliance according to the picture of electric appliance. (See the attached figure 12)
7. **Wire connecting of the load frame right cover**
8. **Mounting of the power supply plug:** Insert the plugs of the power supply and the computer supply source in the board of the general supply.
9. **Level adjustment of the worktable:** when adjusting, put the load frame on the proper position, and then put the 0.02mm/m levelness on the worktable of the testing machine. There are four level- adjusting bolts. Screw one of them downwards, to make the base depart from the supporting board about 25mm. Based on this height, adjusting the depth of the other three bolts downwards, make the levelness of the worktable in the two perpendicular directions for each other within 0.2/1000.
10. **Start-up the power supply**
 11. Turn on the switch of the general power supply.
 12. Turn on the power supply switch of the host computer and monitor.
 13. Turn the power supply switch on the right of the base of load frame to ON.
 14. Double click the software icon of Max Tes that exits on the main interface of the computer, operate the computer according to the *Software Manual*, and then enter into the work interface.
 15. Press the start-up button of the load frame, prepare for the test.
16. **Note:** Because the machine is complex for operation and there are many test parameters, so the technical personnel adjusted and calibrated it before the machine leaved the factory. Hope the user not changing the inner special parameters of the machine. You can normally use this machine according to the manual operation. If there is any question, please carefully read the *Software Manual*.

5 Calibration of the test load and deformation

See the Software Manual

Note:

1. The test load and deformation have been calibrated before the machine leaved factory, there is no need for the user to re-calibrate them. Validity: one year.
2. Before driving the software, collect the all the electric cables well. Not press down the URGENT button.
3. When calibrating the load cell, pay attention to the measuring range of the standard dynamometer and the load cell. Choose the proper standard dynamometer.
4. Choose the proper running speed. Keep the standard dynamometer protected.

6 Mounting and removing of the accessories

6.1 Mounting and removal of the tensile accessories

6.1.1 Mounting of the wedge tensile accessory

Mount the tensile accessory according to the attached figure (5). Please note that the load cell has been equipped well with the machine before leaving the factory, so the user does not remove the load cell at random. When mounting the upper gripping arrangement (6), link the universal joint (3) to the load cell (1) at first, and then link the upper clamps (6) to the universal joint (3) through the fixed pin (4). When mounting the lower clamps (8), connect the locknut (9) to the lower tensile clamps (8) well at first, and then insert the above

two to the base (11) of the flange, connecting them with the fixed pin (10). After that, tighten the locknut (9) to remove the clearance. What's more, when mounting the gripping arrangement, pay attention to the mounting direction of the attachment. Make the concave of the clamps to the operator.

6.1.2 Removal of the wedge gripping arrangement

When removing the upper gripping arrangement (6), lift the upper gripping arrangement (6), and then draw out the fixed pin (4). Take down the upper tensile clamp and then put it in the accessory box. When removing the lower gripping arrangement (8), loose the locknut (9) at first, then draw out the fixed pin (10), Take down the upper clamps and then put it in the accessory box. When removing the gripping arrangement, please note that lift the attachment with enough energy, preventing it from dropping down and damaging the operator.

6.2 Mounting and removing of the compression plates

6.2.1 Mounting of the compression plates

Mount the compression plates according to the attached figure (6). After removing the gripping arrangement, with the locknut (9) connect the connection shaft (7) together with the load cell (8) to a whole. Then fix the upper compression plate (5) to the connection shaft (7) with the locknut (6). When mounting the lower compression plate (3), it is only necessary to put the lower compression plate (3) onto the base of the flange (2) for the general compression test.

Note: 1. When mounting the connection shaft (7), pay attention to the position of the locating pin.

When mounting the upper compression plate (5), press the upper compression plate (5) tightly on the face of the connection shaft (7), to prevent the clearance from appearing of the two parts.

6.2.2 Removal of the compression plates

According to the steps in 9.2.1, take down the parts one by one reversely.

6.3 Mounting and removal of the bend fixture

6.3.1 Mounting of the bend fixture

Mount the bend fixture according to the attached figure (7). Take down the upper compression plate (5), lower compression plate (3) and the base of the flange (2) at first. The bending table (3), locknut (5), and the lower compression roller (6) have been mounted on the worktable; there is no use for the user to mount them. The only thing that needs the user to do is that fix the upper compression roller (7) on the connection shaft (9) with the locknut (8). After the mounting is finished, adjust the locknut (5) to adjust the position of the moving crosshead, to make the centers of the upper compression roller (7) and lower compression roller (9) on the same height. Pull the lower compression roller (6) to make it tightly lean on the two sides of the upper compression roller (7), and then tightly screw the locknut (8). At last, adjust the lower compression roller (6) through the indication of the staff gauge, to make it locate on the proper position. Tightly screw the locknut (5), put the specimen well, and then do the bending test.

Note: When mounting the upper compression roller (7), it is needed to press the upper compression roller (7) tightly on the locknut (9), to prevent the clearance from appearing between the two parts.

6.3.2 Removal of the bend fixture

Loosen the locknut (5), pull the lower compression roller (6) to the end along with the T slot, with the distance not impacting other tests. Tightly screw the locknut (8), take down the lower compression roller (7), and put it in the accessory box. When necessary, take down the bending table (3), to avoid impacting other tests.

6.4 Mounting and removal of the shear fixture

6.4.1 Mounting of the shear fixture

At first take down the upper compression plate (5) and the lower compression plate (3), Mounting the shear fixture according to the attached figure (8). With the locknut (8), the user can fix the shearing pressure head on the connection shaft. Put the base (3) of the shearing on the base (2) of the flange, and mount the knife (4), specimen (5) and the

base (6) of the support. After finish the mounting, loosen the locknut (8), adjust the position of the moving crosshead, make the arc centers of the shearing pressure head (7) and the knife edge (4) on the same direction. At this time, tightly screw the locknut (8), and then do the shearing test.

Note: When mounting the shearing pressure head (7), it is necessary to tightly press the shearing pressure head (7) on the face of the connection shaft, to prevent the clearance from coming between the two parts.

6.4.2 Removal of the shear fixture

Loosen the locknut (8), take down the shearing pressure head (7), and put it in the accessory box. Then take down the base (3) of the shearing, and put it in the accessory box.

7 Operation

7.1 Operation and notices

7.1.1 Operation

Turn on the computer and the monitor, make the computer enter into the Windows operating system. Click and enter into the application program interface. Software operation refers to the **SOFTWARE MANUAL**. According to the rotation direction indicated in the clamps, clamp the specimen on the upper insert. Choose the crosshead moving speed as 50mm/min in the computer. Adjust the position of specimen in the lower insert, the zero of the test loads, and clamp the lower insert.

If necessary, clamp the extensometer on the specimen with the rubber band, and remove the adjustment mat. Adjust the deformation zero that the specimen.

Choose the proper automatically controlled test program or manual operation, control the down moving of the crosshead. (Regarding to how to set the automatically controlled program, please see the **SOFTWARE MANUAL**.)

During the tension, pay attention to the shape of the curve. If there is an extensometer in the test, it is needed to set a value, and at that point the extensometer will be removed (For details, please see the **SOFTWARE MANUAL**). When the specimen deformation reaches the set value, the user should remove the extensometer according to the indication of the test software, to prevent the extensometer from damaging.

After the test is finished, the testing machine stops automatically. The user is needed to enter into the data processing interface for data processing. (For details, please see the **SOFTWARE MANUAL**)

Screw the handle according to the indication on the clamps, and then loosen the specimen.

Print or store the processing result, and a whole test is finished.

Notices

Before starting up the testing machine, it is necessary to check the position of the limit knob, ensuring to make it contenting the demand of test travel, and avoid the bumping of the upper and lower clamps. The limit switch mounted on the middle crosshead moves together with the middle crosshead.

The rotation direction of the gripping arrangement handle has been indicated on the attachment. When exchanging the inserts, please put the round pin of the inserts in the guide slot on the back of the clamps. The front catch cannot be pressed too tight, to avoid blocking the inserts. When the exchange is finished, the inserts should be moved by the hand.

Place the adjustment mat when clamping the extensometer, and take it carefully, protecting the knife edge from damaging. It is prohibited to pull the lead wire.

During the test, take down the extensometer according to the indication of the software, to prevent the extensometer from distortion and the damage when the extensometer broken.

During the test, if testing $R_p0.2$, the user must choose the extensometer deformation when starting this test, clamping the extensometer on the specimen. Or, choose the displacement instead of the deformation when starting the test, but the measurement is not accurate.

The red mushroom-shape button on the load frame is for the urgent matter. Press it when emergency.

If the crosshead moves to the limit mechanism, the testing machine will stop automatically. If re-start up the testing machine, the operator should loosen the limit adjustment knob at first, and move it to the required position. Or, the machine cannot be re-started up again.

7.1.2 Maintenance

The testing machine belongs to the precise testing equipment. It is necessary to pay attention to the maintenance. It is especially needed to avoid the water and humidity. Prevent the machine, the transmission mechanism, the cover and the accessories form rusting.

1. If the testing machine has been not used for a longer time, it is necessary to electrify the machine to drive the moving crosshead up and down a certain time (not more than one week). Make the crosshead and bolt & nut regularly move to avoid rusting.
2. If overloaded during the test, please cut off the power supply at first and then re-electrify the machine. Pay attention to the order of cutting off and electrifying. When cutting off the power, please cut off the drive power supply at first, then exit the computer internet applications, and at last turn off the power of computer.
3. If the test load and deformation monitor are not instable, or the testing machine cannot be driven, please contact the manufacturer for maintenance.

7.1.3 Normal trouble and the way of removal

Normal trouble of the load frame and the way of removal

Serial No.	The Trouble	Cause of the trouble	Way of removing the trouble
1	The machine cannot ascend or descend.	The limit switch is working. The limit switch is damaged or wire broken. The URGENT switch is damaged or wire broken. The power supply lacks one phase. Overload of the speed-regulating system.	Remove the limit switch Exchange the limit switch or repair the broken wire Exchange the Urgent switch or repair the broken wire Check and repair the power supply 5. Check the cause of overload and remove the trouble. Then electrify the machine again.
2	The test load is overload	The load cell is damaged The wire of the load cell is broken or the socket is not reliable	Exchange the load cell Repair the broken wire or check the socket
3	The software does not work normally	The computer is infracted by the virus	Remove the virus with the virus-kill disk Copy over again with the backup disk



Fig. 1: View of WDW-50

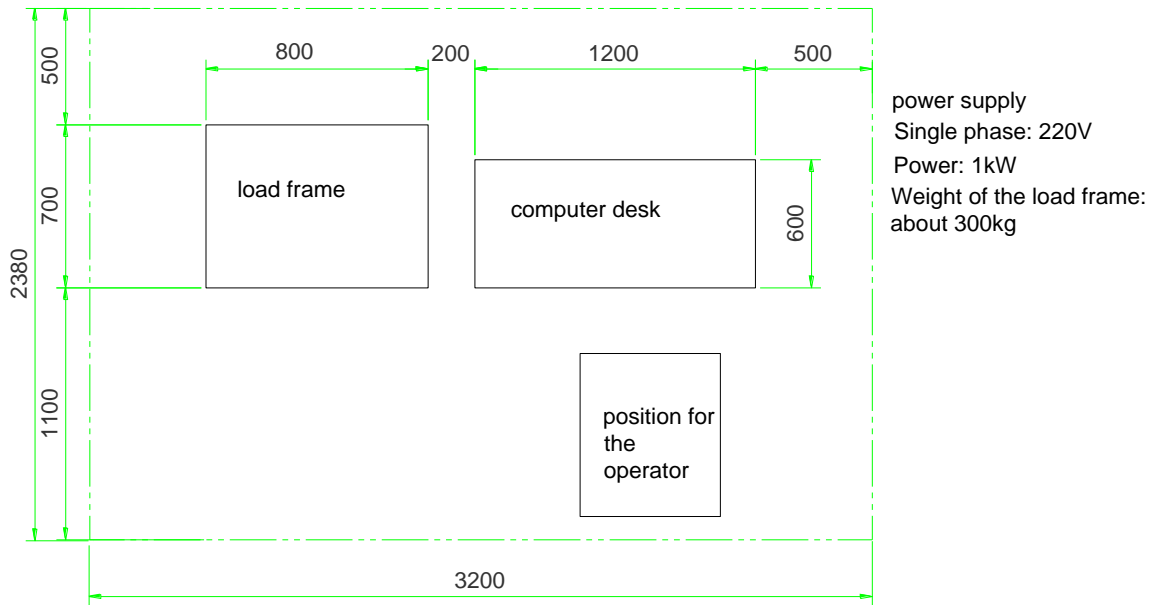

- Note: 1.The two-dot chain line zone requires to be provided with plane
 2.Foundation is not required, but flat cement floor is demanded.
 3.Space height is not less than 3000mm

Fig.2 Foundation picture of WDW-50

- 1.upper part of the load frame
- 2.middle part of the load frame
- 3.lower part of the load frame

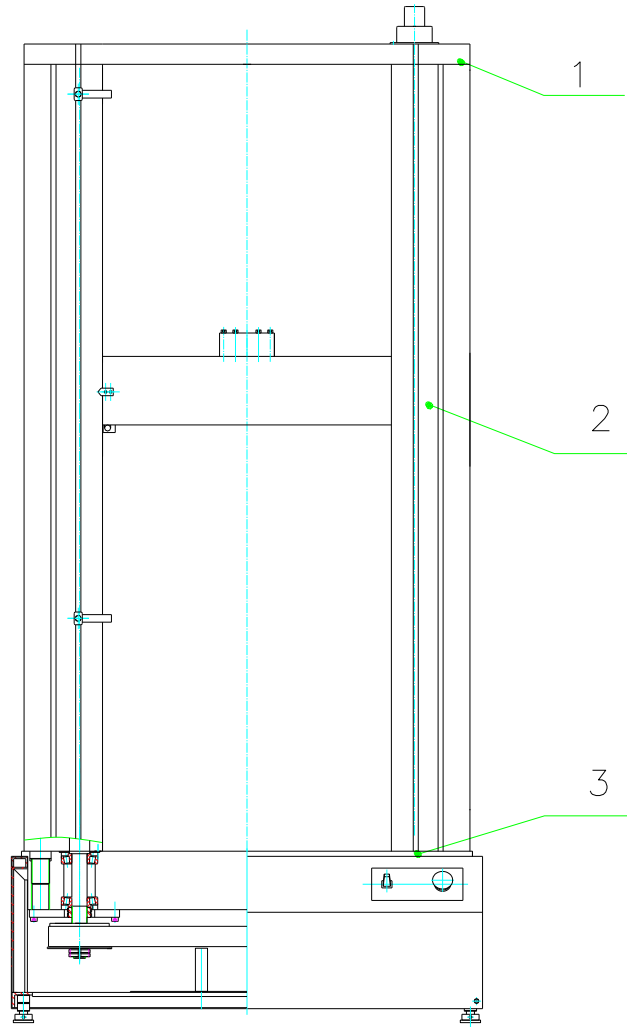

fig.3: load frame

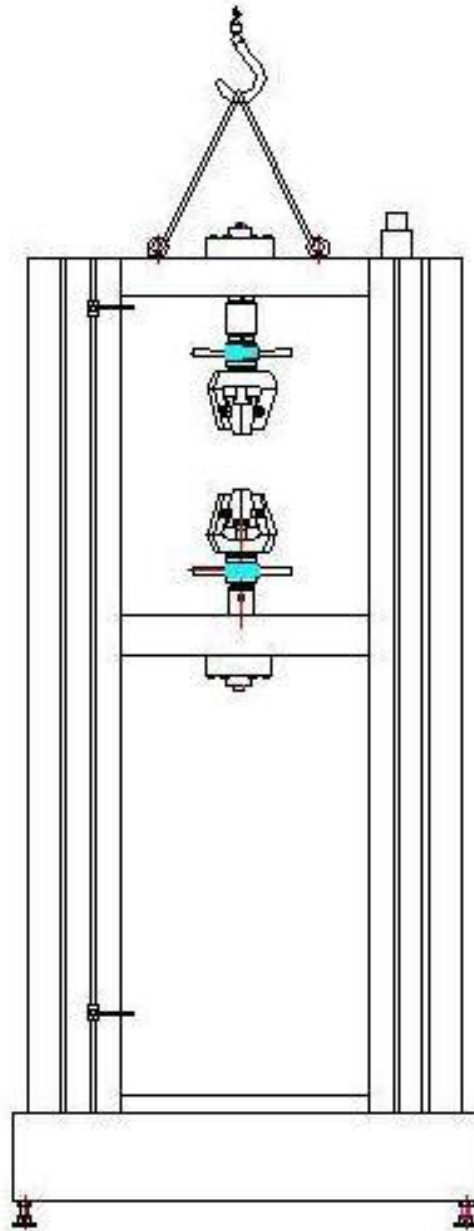
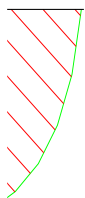

Fig.4 Vertical lifting picture of load frame



1. worktable
2. base of the flange
3. lower compression plate
4. specimen
5. upper compression plate
6. locking screw
7. connection shaft
8. load cell
9. locknut



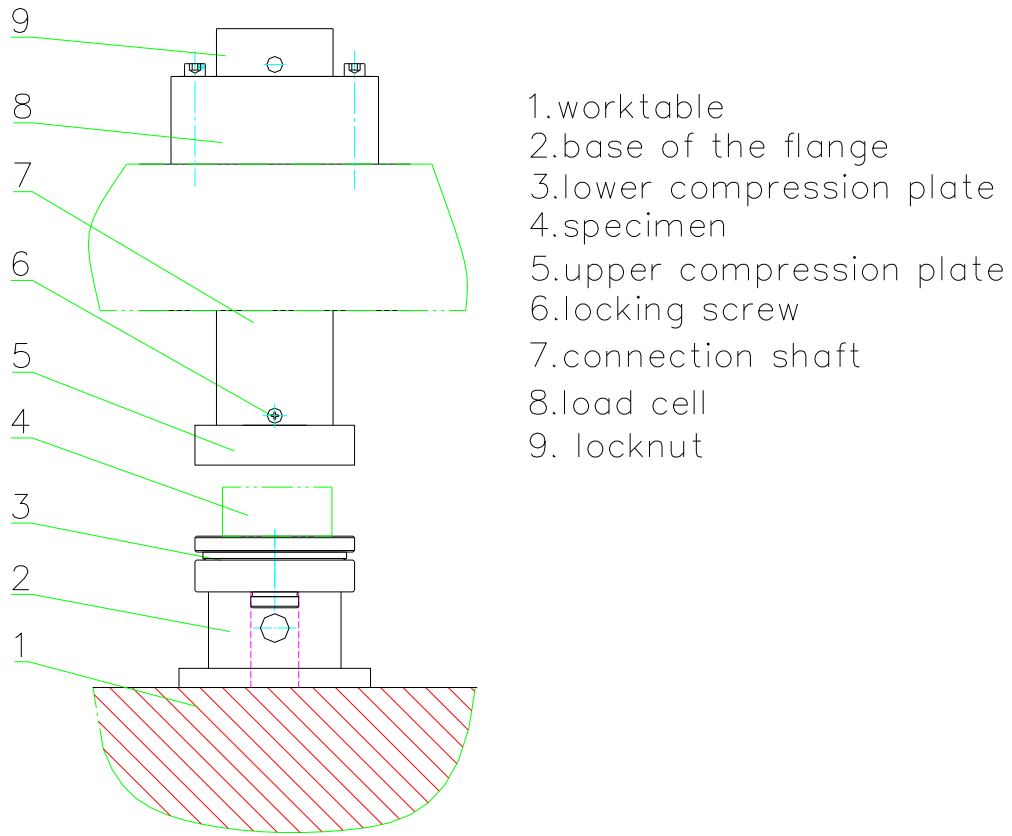
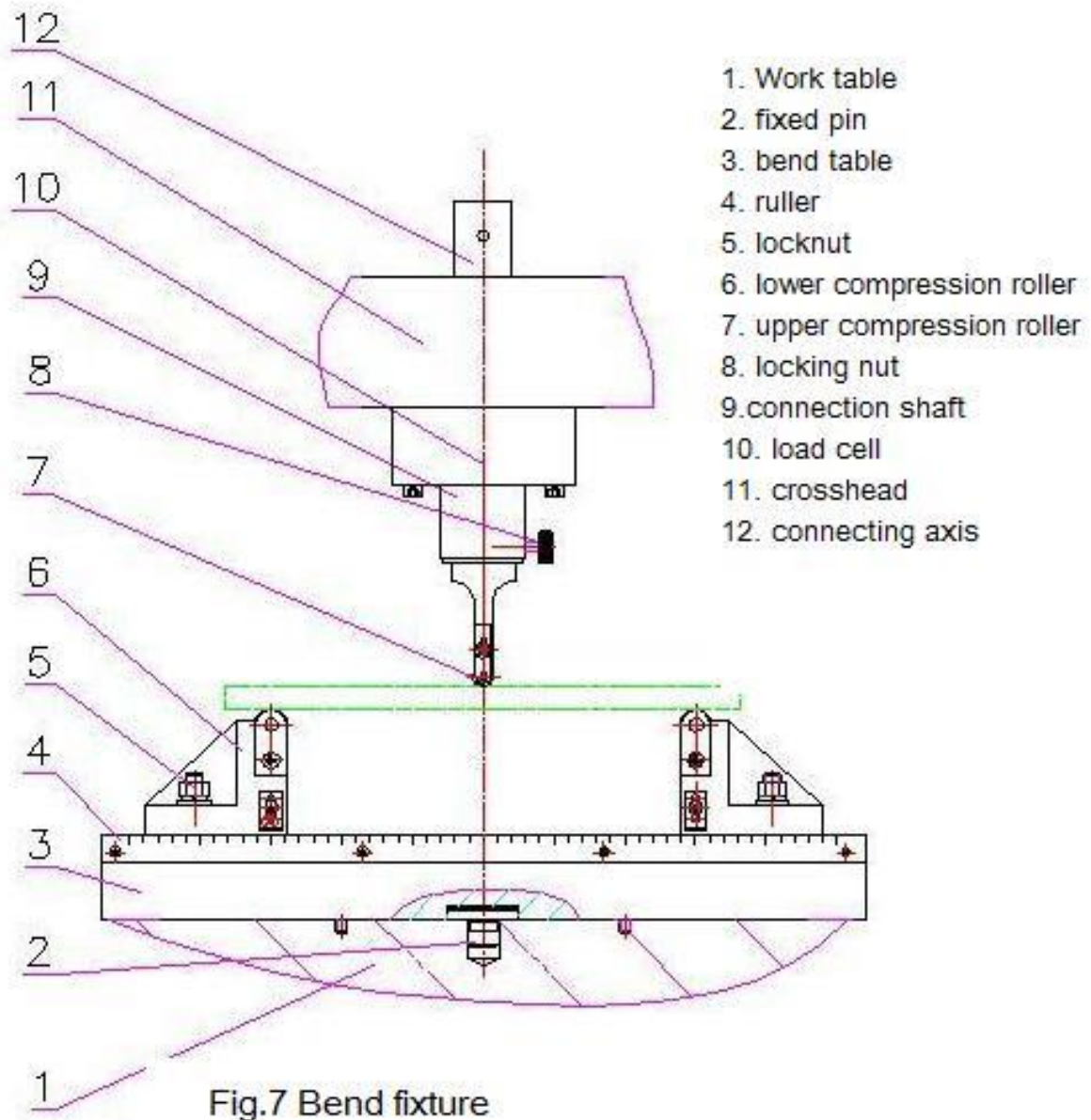

fig.6 – – compression plates



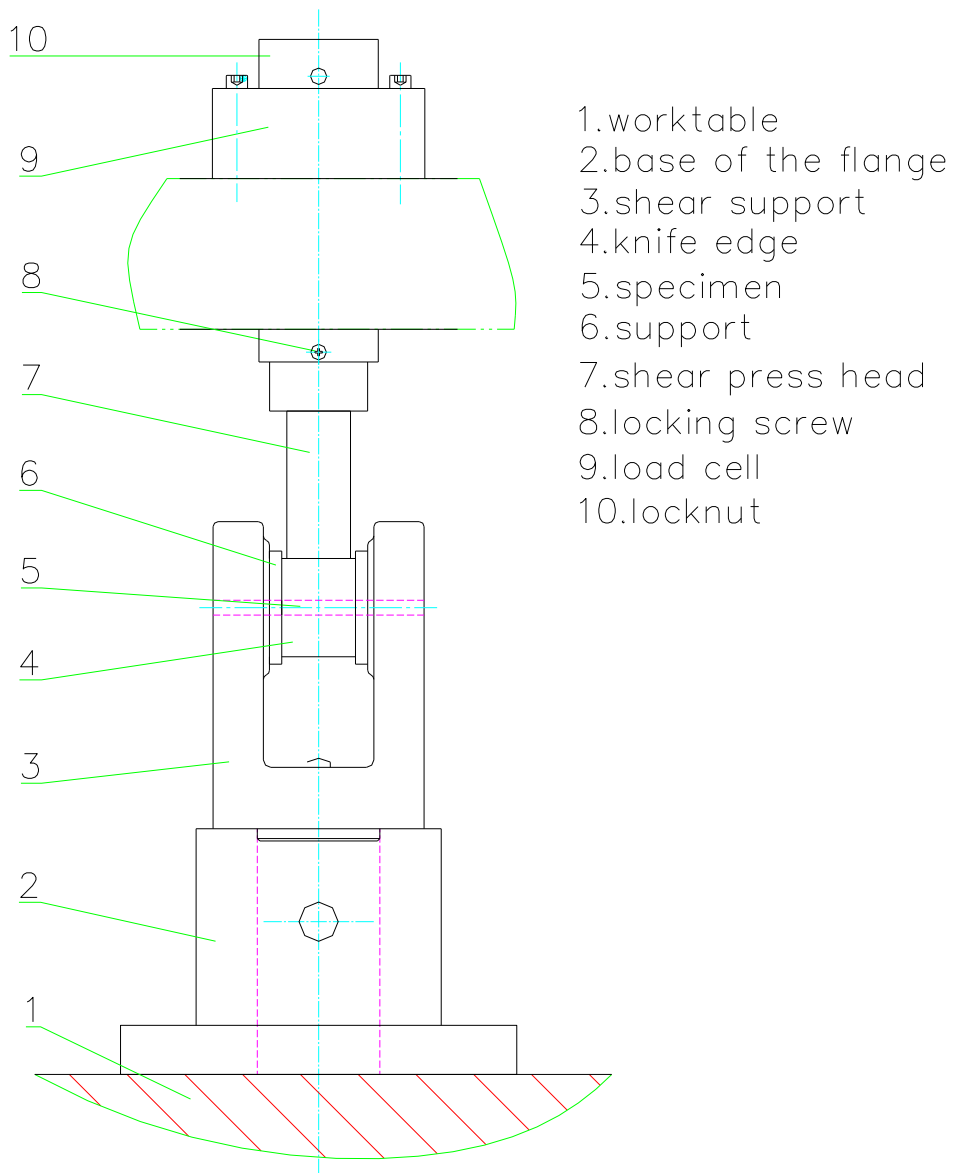

fig.8: Shear Fixture

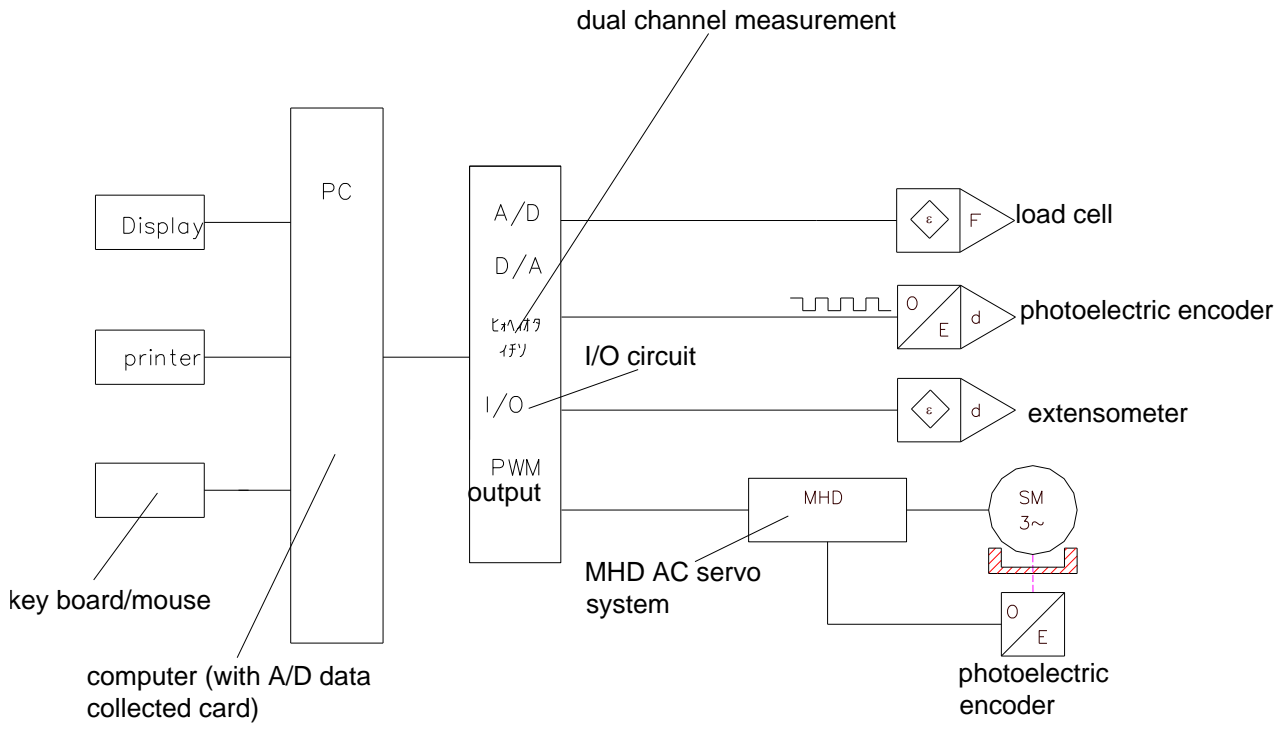

fig.9 system chart

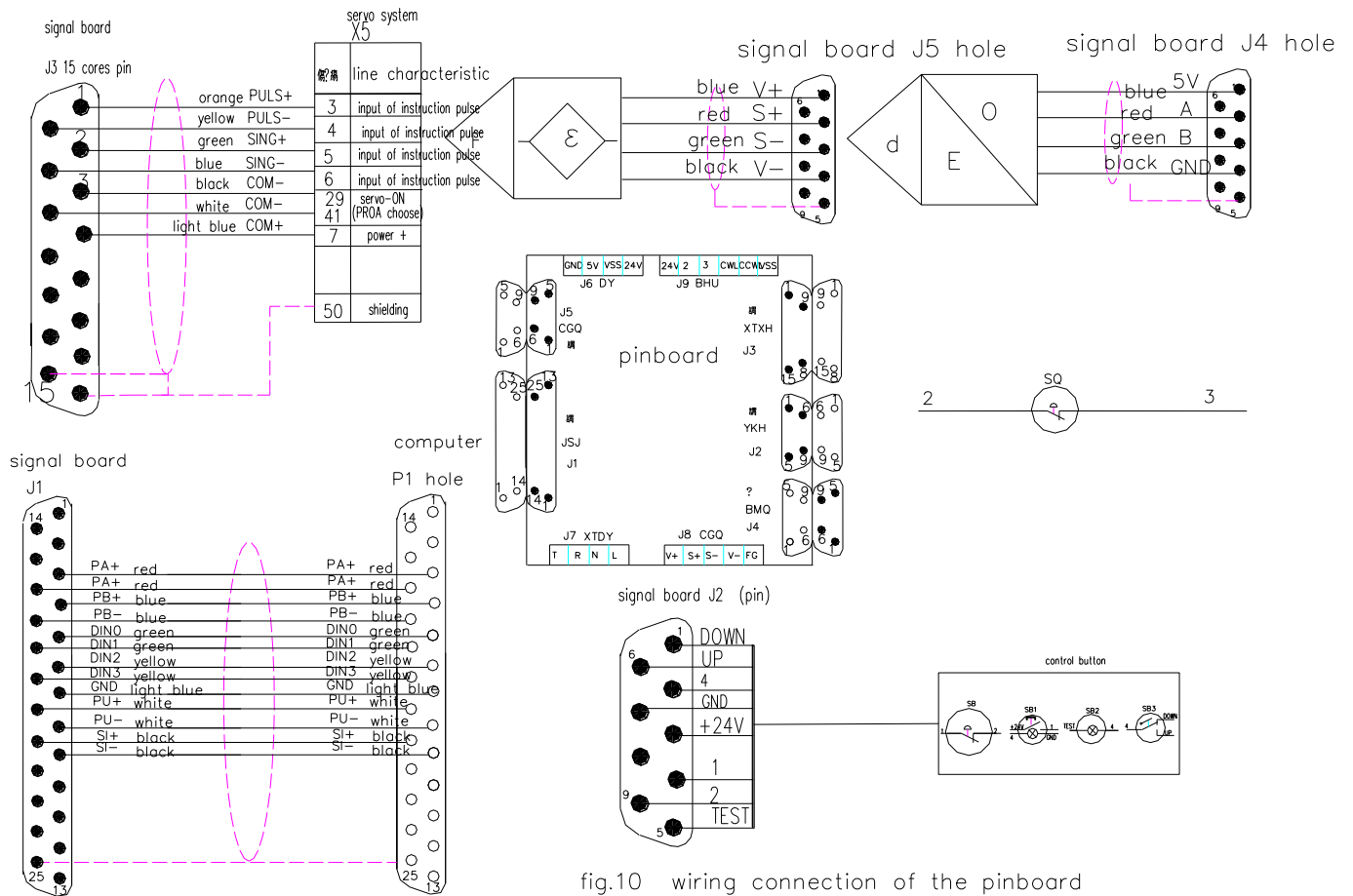
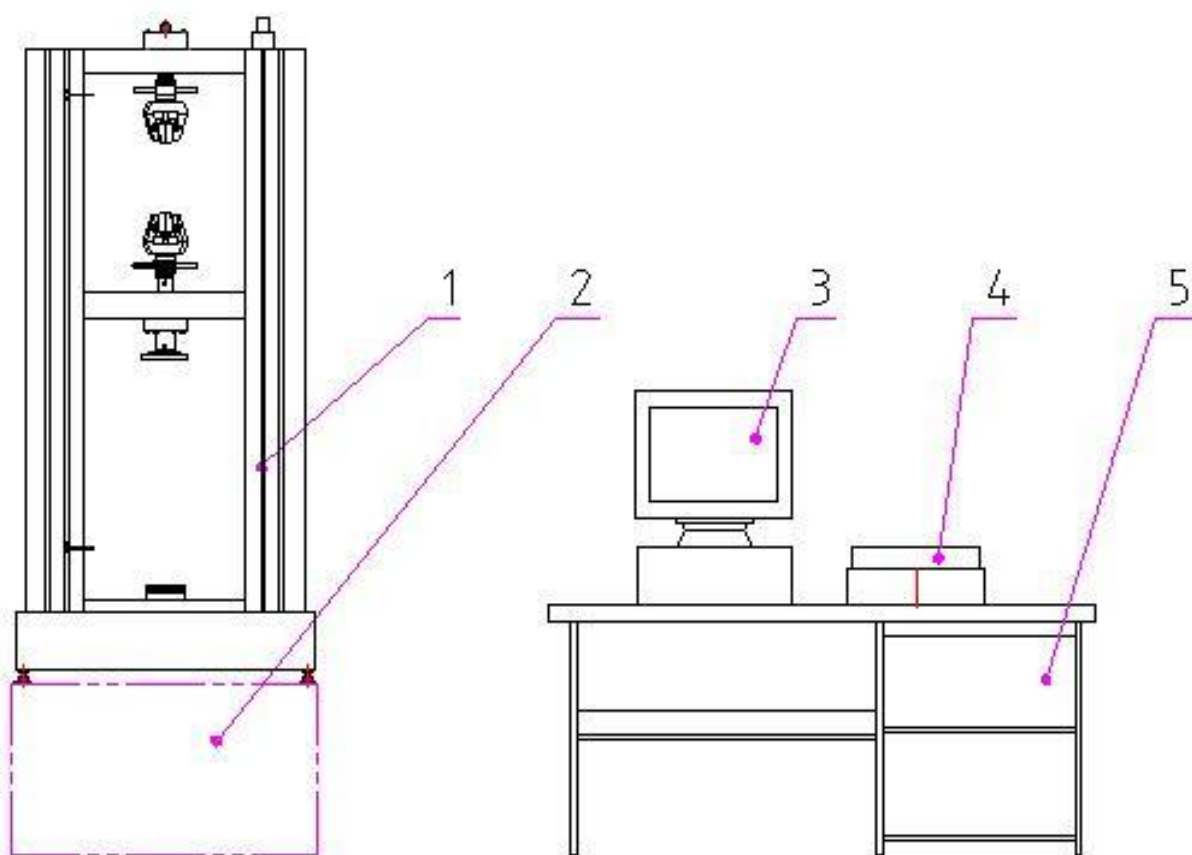

fig.10 wiring connection of the pinboard



1. Load frame. 2. Support table. 3. Computer. 4. Printer. 5. Computer desk

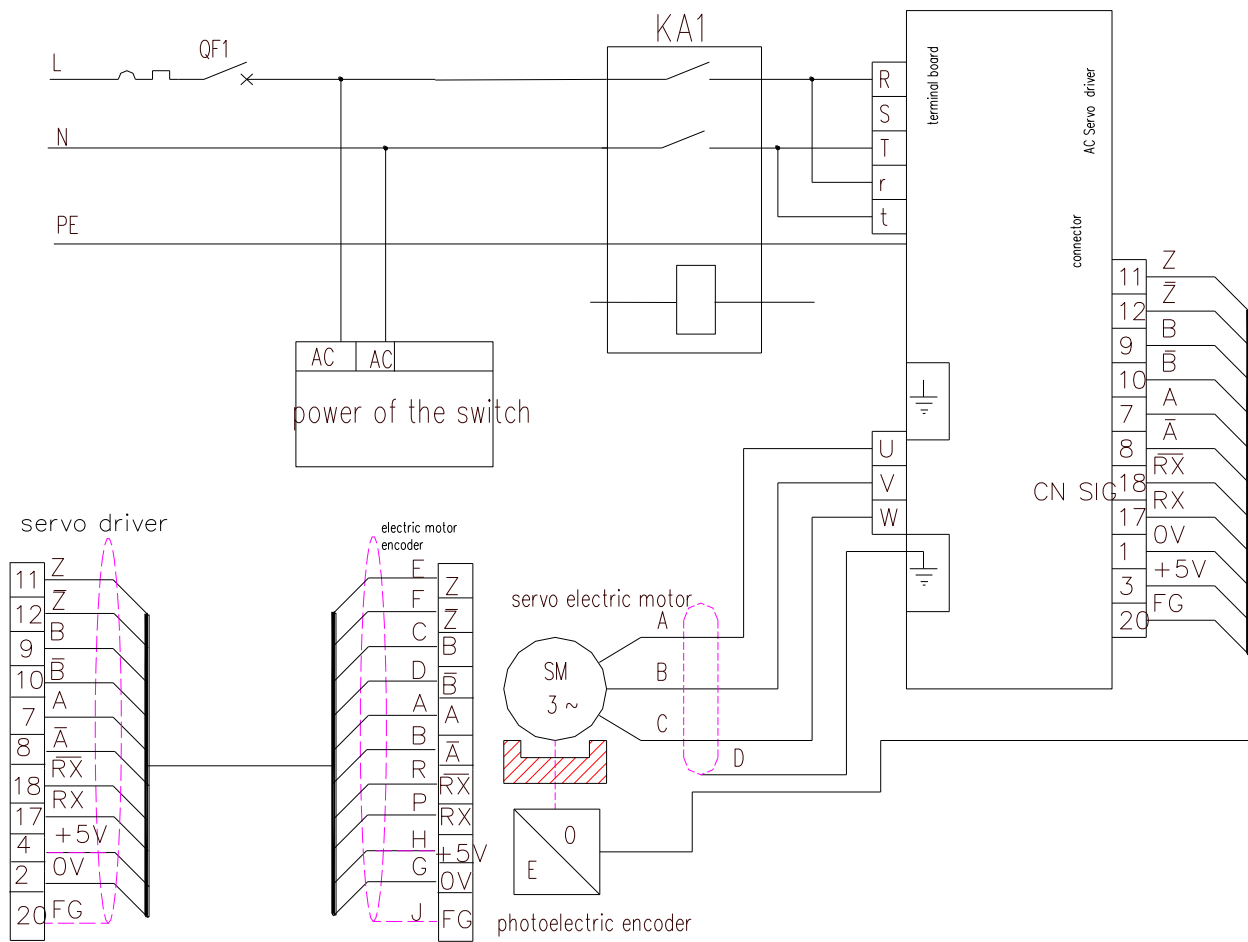

fig.11 circuit of the power system

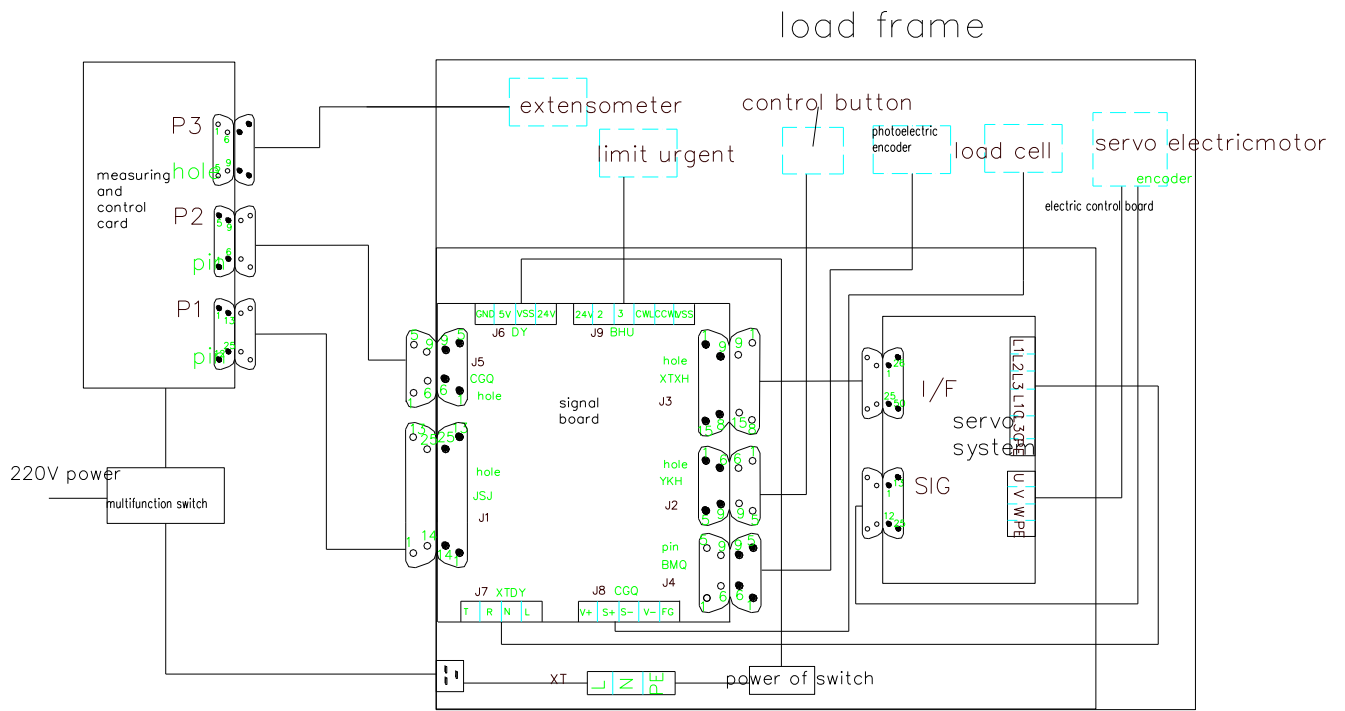

fig.12 wiring connection of the system interface