



# WEBSTER ALUMINUM PORTABLE HARNESS TESTER



**Bms Bulut Makina Sanayi Ve Ticaret Ltd. Şti.**

İkitelli Organize Sanayi Bölgesi Dolapdere Sanayi Sitesi

Ada 4 No : 7-9 İkitelli / İSTANBUL-TÜRKİYE

Phone : +90 212 671 02 24 / 671 02 25 Fax : +90 212 671 02 26

web : [www.bulutmak.com](http://www.bulutmak.com) e-mail : [bms@bulutmak.com](mailto:bms@bulutmak.com)

Technical Specifications .....	3
Accessories.....	3
Principle Of Operation .....	4
Zero And Load Spring Adjustments.....	5
The Zero Adjustment.....	5
Load Spring Adjustment .....	5
Making The Test .....	6
Disassembly .....	6
Special Instructions For The Model Wb Tester .....	7
Special Instructinons Model W-B75 Tester.....	9
Special Instructions Model W-Bb75 Tester.....	10
Repair And Replacement.....	10

## Technical Specifications

Display	<b><i>Webster dial gauge</i></b>
Max test height	<b><i>6.35 mm</i></b>
Depth of throat	<b><i>12 mm</i></b>
Accuracy	<b><i>± 1</i></b>
Measuring range	<b><i>0-20 Webster</i></b>
Hardness scales	<b><i>Webster</i></b>
Machine dimensions	<b><i>200 x 285 x 25 mm</i></b>
Case dimensions	<b><i>250 x 185 x 75 mm</i></b>
Weight (net/gross)	<b><i>0.45 / 0.9 kg</i></b>

## Accessories

Instruction Manual 1  
Webster Test Strip 1  
Carrying Case 1

Webster Hardness Testers are made in three distinct models. All operate in the same manner but differ in penetrator design, type of reading and range of hardness accommodated. The first few pages of this manual cover principles common to all types of Webster hardness testers. Specific instructions on individual types follow immediately thereafter. This instruction manual is written to provide a clear understanding of the use and maintenance of Webster Hardness Testers. By closely following the instructions contained herein, the least amount of lost production time will result due to returning the tester to the manufacturer for repair or adjustment.

## Principle Of Operation

All models of the Webster Hardness Tester operate in the same manner. The work to be tested is placed between the anvil and penetrator. Pressure is applied to the handles until "bottom" is felt at which time the dial indicator is read. Excess handle pressure beyond this point is not harmful but is unnecessary.

The Tester should be held still while taking the reading as any twisting or other movement during test will result in untrue readings as experienced with any other hardness testing machine.

By reference to cutaway view Fig.1 it will be seen that the principal working parts are contained in the penetrator assembly. The penetrator assembly consists of the penetrator, load spring, adjusting nut, penetrator housing, housing key, return spring and dial indicator. This entire assembly moves toward the anvil as a unit when pressure is applied to the handles.

As handle pressure is applied and the penetrator assembly moves toward the work, the penetrator point makes contact first because it projects beyond the flat face of the housing. Continued handle pressure causes the penetrator to recede into the housing against the load of the load spring.

**FIG.1**



**Fig.1**

"Bottom" is felt when the flat lower end or face of the housing rests against the work at which point further pressure on the handles simply squeezes the metal between the housing face and the anvil. At this point the only load on the penetrator is that of the load spring which is governed by the setting of the load spring adjusting nut.

The dial indicator is fitted to the upper end of the penetrator housing and is actuated by the movement of the penetrator. On metal of extreme hardness the penetrator will recede into the housing until the tip is flush with the housing face. This is the position of maximum penetrator travel and is used for "zero" or full scale setting of the dial indicator. It is obtained by completely compressing the penetrator against the bare anvil. This will be explained in detail later (see zero adjustment page 4) On metal of

extreme softness the penetrator will not recede into the housing at all, there will be no movement of the penetrator and no reading will be obtained on the dial indicator.

## **Zero And Load Spring Adjustments**

There are only two adjustments on the Webster Hardness Gauge regardless of model; the zero adjustment of the dial indicator and the load spring adjustment. The zero adjust screw atop the dial indicator case shown in Fig. 2 is adjusted at the factory to take care of the accumulated tolerances of a particular penetrator, housing and dial indicator. It need never be adjusted unless one of the reasons shown on page 4 is present and then only if the indicating hand does not reach full scale when the tester is operated against its bare anvil. Care must be exercised in making the adjustment in that the screw should not be turned until after the handles are depressed fully. This prevents the possibility of the indicating hand passing full scale, striking the case and applying high torque to the internal mechanism of the indicator.

### **The Zero Adjustment**

The method of making the zero adjustment of the dial indicator is shown in Fig. 2. With the tester operated against the bare anvil, and handle pressure maintained, the zero adjusting screw is slowly turned until the hand of the dial indicator rests on the zero line of the dial face, which is full scale reading. This zero line is at 20 on the W-20, W-B75 and W-BB75 models.

After this zero adjustment has been properly made it should never be changed except for one of the reasons listed below:

Where a new penetrator is installed.

Where the dial indicator is changed from one penetrator to another.

Where excessive wear has resulted in need for a slight adjustment.

The operator can instantly check for correct zero adjustment by operating against the bare anvil and noting whether the hand comes to rest on the zero line.

The zero adjustment should never be changed for any other reason and it is extremely important that the operator be warned of this fact. Never use the zero adjustment to make the tester read correctly on the standard sample but adjust the load spring, as described below.

### **Load Spring Adjustment**

The load spring adjustment is the same for all models. The special wrench provided with each tester is used as shown in Fig. 3 to vary the load on the penetrator by applying more or less pressure on the load spring. This is accomplished by rotating the adjustment nut. It is this

**FIG .2 Zero adjustment screw “A” is indicated by arrow**



**Fig.2**

load spring adjustment that is used to standardize the reading to agree with that of the standard sample furnished with all models. If a reading taken on the standard sample does not agree with the number stamped on it, the load spring should be adjusted so that the reading obtained will be the same as marked on the standard sample.

## **Making The Test**

Each model is provided with a round anvil to facilitate testing of tubes, shapes or formed parts as well as sheet and strip. In checking tapered sections such as are found in some extrusions, the tester should be applied in such a way that the anvil bears along a line which is parallel to the surface in contact with the penetrator. The right and wrong way of checking such sections is shown in Fig. 4 page 6.

On flat work such as sheet and strip no special instruction is necessary as the metal to be tested is simply inserted between the anvil and penetrator. Pressure is applied to the handles until “bottom” is felt and the dial reading taken.

## **Disassembly**

The entire tester can be taken apart for inspection or repair by removing the pivot screw and withdrawing

**FIG.3 Adjusting load on load spring**



**Fig.3**

the handle. The penetrator assembly should be held downward with the thumb to facilitate removal of the handle. After handle is removed the entire penetrator assembly is easily lifted from the frame. The dial indicator may then be lifted from the housing and the load spring adjusting nut backed off and removed with the special wrench provided. This will relieve the load on spring and permit spring and penetrator to be removed. The return spring will be found in the hole provided for it in the frame and the housing key is easily detached from the housing. The dial indicator should not be taken apart unless an experienced instrument repair man is available.

**FIG.4 Making the test**

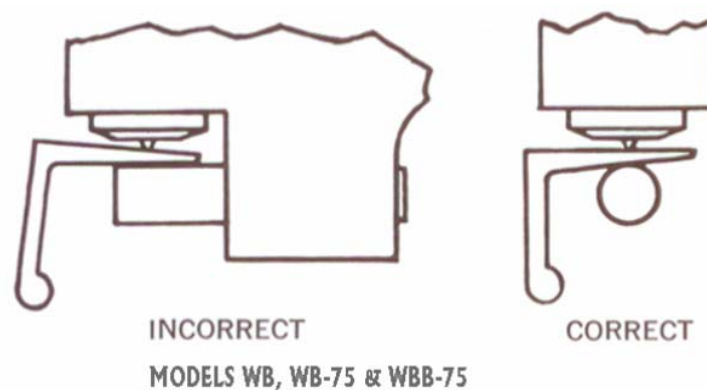

**Fig.4**

### **Special Instructions For The Model Wb Tester**

The model W-20 Tester has a single point penetrator which can be identified from Fig. 5. The dial indicator is graduated 1 to 20 and the hardness readings obtained can be compared to other hardness readings such as Rockwell and Brinell. As in all

models the amount of load exerted on the penetrator is determined solely by load spring adjustment and is not affected by excess handle pressure. The handle pressure required to operate the model W-20 Tester is the lightest of any of the three models. This tester is designed for use on aluminum and its alloys but may also be used for other metals in that hardness range.

Each model W-20 Tester is accompanied by a standard sample stamped with the proper dial indicator reading. This sample is to be used for routine check to insure proper load spring adjustment. Before making such check the dial indicator must be in proper zero adjustment (see page 4). If the reading on the dial indicator does not agree with the number stamped on the standard sample, slight change must be made in load spring adjustment until readings agree. When adjusted properly the readings obtained on aluminum samples are approximately as shown in chart Fig.6.

**FIG.5 PENETRATOR IDENTIFICATION**

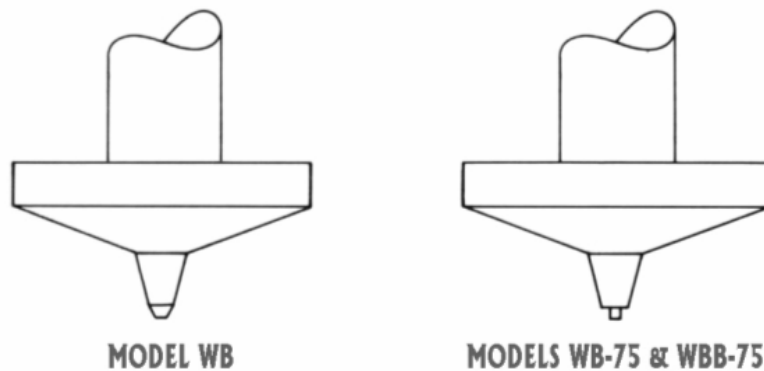

*Fig.5*

**FIG.6 Hardness Range, Aluminum-Model WB**

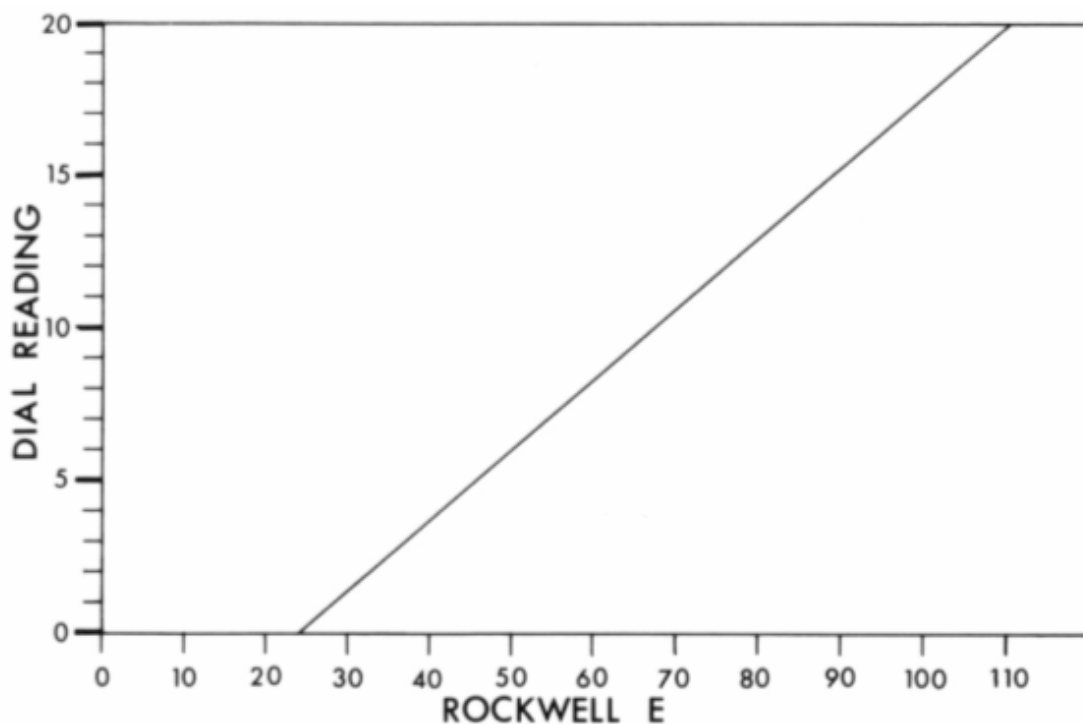

*Fig.6*



## Special Instructinons Model W-B75 Tester

The model W-B75 Tester has a single point penetrator with a different contour from the model W-20 which can be identified from Fig. 5. The same dial indicator is used for the W-20 and W-B75 Tester.

Graduations are 1 to 20 . Hardness readings obtained with the model W-B75 can be compared to other standard hardness readings such as Rockwell, etc.

As in all models the amount of load on the penetrator is determined solely by the load spring adjustment and is not affected by excess handle pressure.

The Model W-B75 uses a slightly heavier load spring that the Models W-20 and W-BB75 but requires very little more pressure on the handles to operate.

The W-B75 Tester is designed for use on brass and mild steel and the 20 dial graduations will cover the hardness range from annealed to full hard brass. The W-B75 Tester is more sensitive than the model W-20 and therefore covers a smaller range of hardness.

Each W-B75 Tester is accompanied by a standard sample stamped with the proper dial indicator reading. This sample is to be used for routine check to insure proper load spring adjustment. Before making this check be sure the dial indicator is in proper zero adjustment.(See page 4).

If the reading taken on the standard sample does not agree with the number stamped on it load spring adjustment must be changed to make reading agree.

With proper zero and load spring adjustment, readings obtained on brass and mild steel samples are approximately as shown in chare Fig. 7.

**FIG.7 Hardness Range, Brass-Model WB-75**

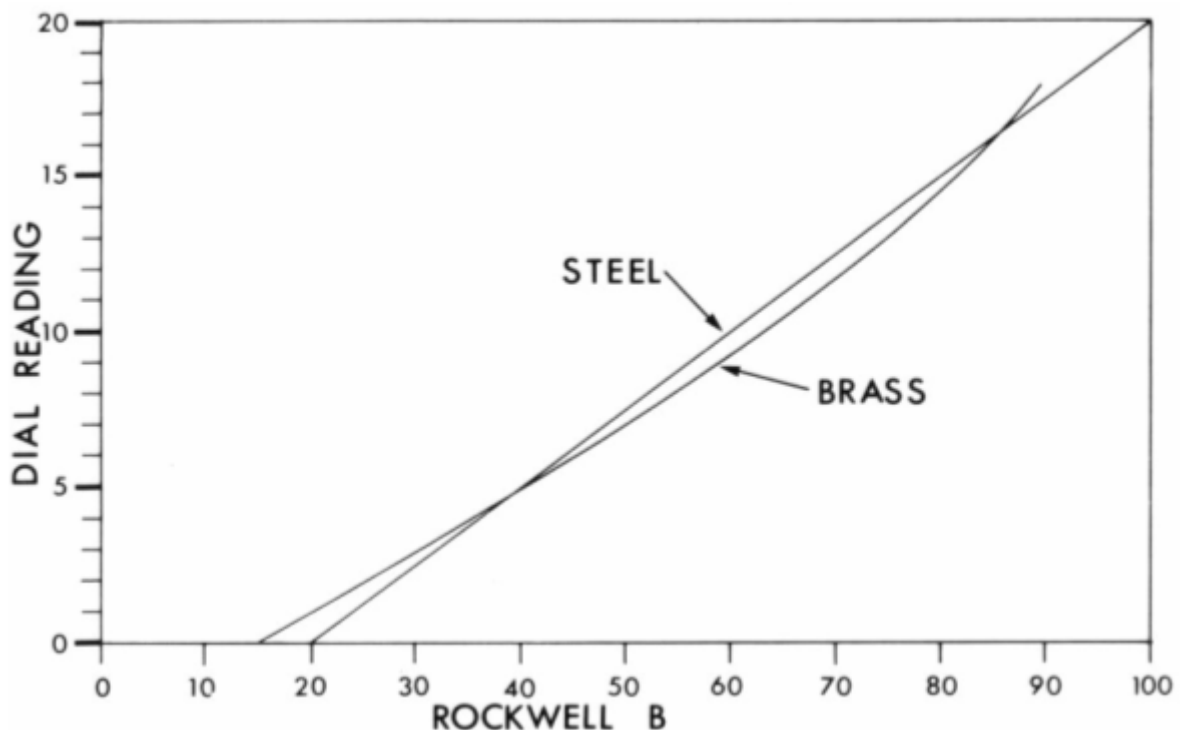

**Fig.7**

## Special Instructions Model W-Bb75 Tester

The Model W-BB75 tester is a combination of the Model W-B75 penetrator and the Model W-20 load spring. This combination provides slightly more sensitivity on the softer materials than the W-20 and W-B75. The Model W-BB75 was developed to answer the need of certain industries for rapidly testing the hardness of electro-deposited copper and copper in the low hardness range.

When adjusted properly the readings obtained on copper samples are approximately as shown in chart Fig. 8.

**FIG.8 Hardness Range, Copper-Model WBB-75**

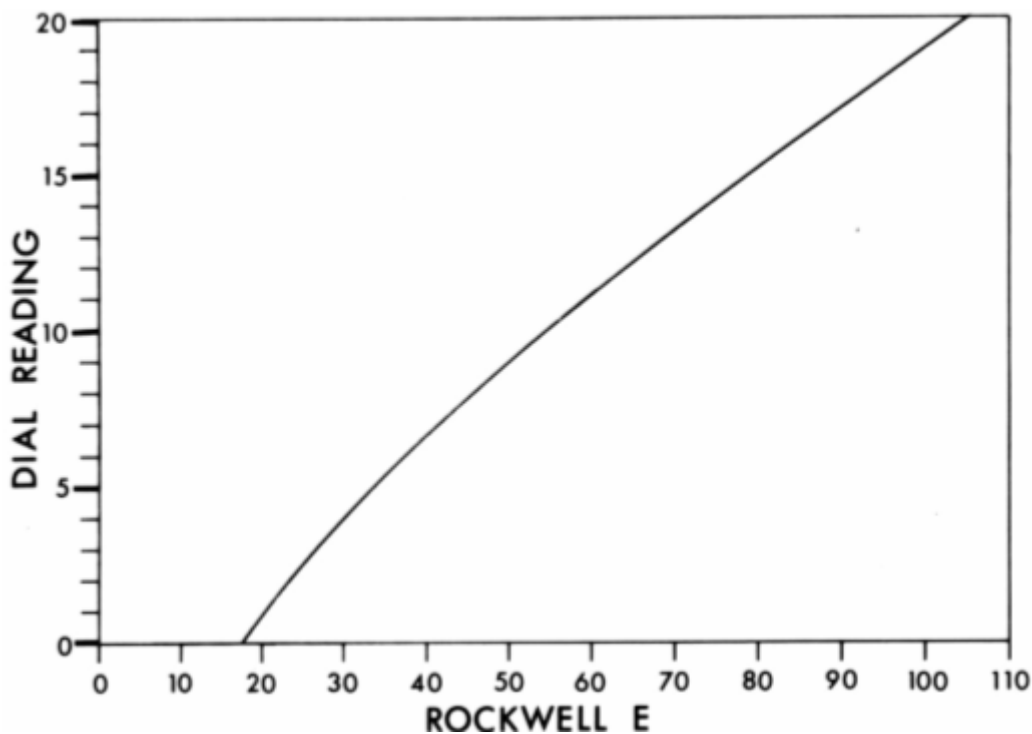

*Fig.8*

## Repair And Replacement

Cutaway view Fig. 9 clearly shows the working parts of the various testers. Each tester has a serial number stamped on the frame and this number should be mentioned in all correspondence relative to repair. The model designation is stamped before the serial number and this designation must be observed when ordering parts or making repairs.

Penetrators should be examined periodically for wear with a magnifying glass. Penetrators showing appreciable wear should be replaced with new ones.

For purpose of clarification the following few points are added:

The penetrator housings for all models are identical.

The dial indicators for all models are identical.

All models employ single point penetrators but are different in contour and should never be used interchangeably.

The load springs for Models W-20 and W-BB75 are identical.

The Model W-B75 uses a heavier spring.

Return springs for all models are identical.

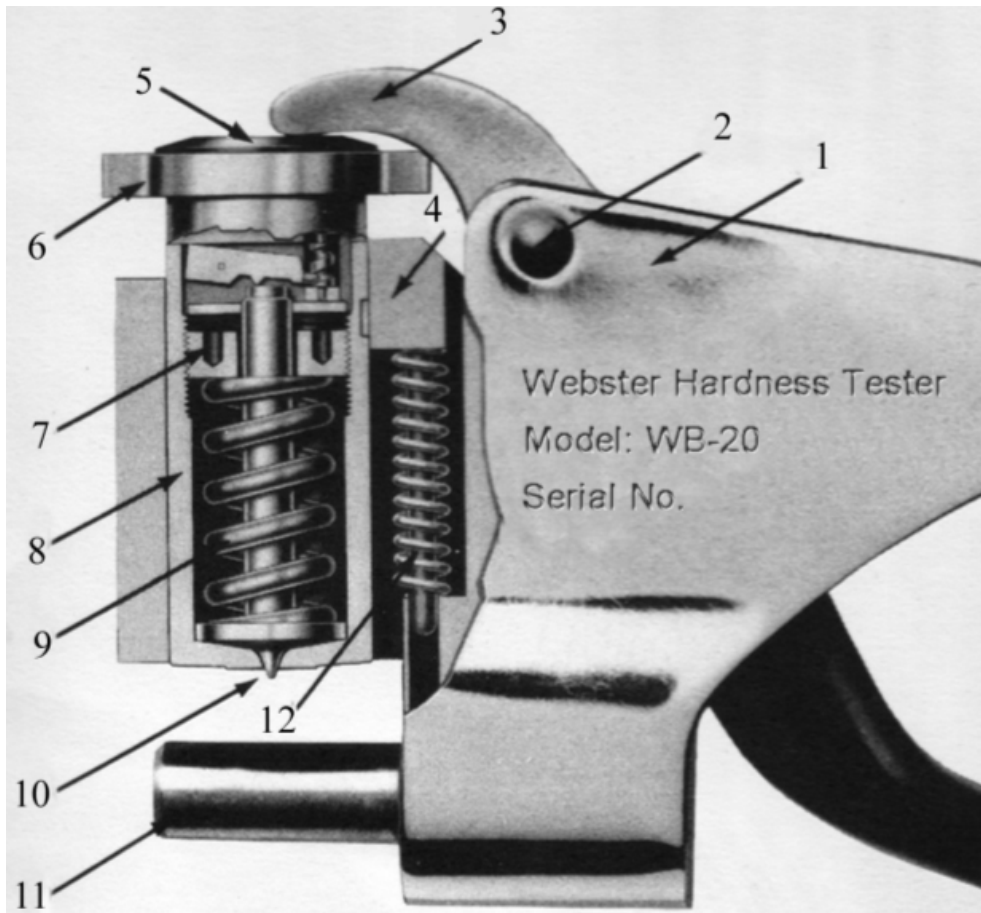

**Fig.9**

**WEBSTER HARDENESS TESTER**  
**Parts List for Models W-20, W-B75 and W-BB75**

<b>1</b>	Frame	<b>7</b>	Adjusting Nut
<b>2</b>	Pivot Screw	<b>8</b>	Penetrator Housing
<b>3</b>	Handle	<b>9</b>	Load Spring
<b>4</b>	Housing Key	<b>10</b>	Penetrator
<b>5</b>	Zero adjustment screw	<b>11</b>	Anvil
<b>6</b>	Dial indicator Assembly	<b>12</b>	Return Spring